

# Jaw couplings

Jaw couplings provide a cost-effective solution for standard power applications, cushioning moderate shock loads and dampening low vibration levels.

Maintenance-free and easy to install, jaw couplings are available with a “snap wrap” element allowing element replacement in situ.

Urethane and hytrel elements have a greater power rating than nitrile elements and are recommended for applications where a compact, high torque solution is required.

## Selection

### 1 Service factor

Determine the required service factor in tables **9** and **10** on pages **87** and **88**.

### 2 Design power

Multiply normal running power by the service factor. This gives the design power for selecting a coupling with a nitrile element.

### 3 Alternative elements

To allow coupling selection based on one power rating table (nitrile), an element correction is required to give a new reference design power. This is done by dividing the design power calculated for a nitrile element by the alternative element power factor listed in **table 1**.

### 4 Coupling size

Using **table 2** on **page 76**, search for the appropriate speed until a power greater than the design power is found. The required jaw coupling is given at the head of the column.

### 5 Bore size

Using product table on **page 78**, check that the selected flanges can accommodate both the drive and driven shaft.

## Example

A jaw coupling is required to transmit 4 kW from an electric motor running at 300 r/min to a centrifugal fan for 12 hours per day. The motor shaft is 20 mm diameter and the pump shaft diameter 18 mm.

### 1 Service factor

From **table 9** on **page 87** = 1.0.

### 2 Design power

Design power = 4 × 1.0 = 4 kW

### 3 Coupling size

When looking for for 300 r/min in **table 2** on **page 76**, the first power figure to exceed the required 4 kW of step 2 is 4.7 kW. In this case, a nitrile element can be used with a jaw coupling size 150.

### 4 Bore size

By referring to the product table on **page 78**, it can be seen that both shaft diameters fall within the bore range available.

## Engineering data

### Power ratings

Maximum torque figures should be treated as short duration overload ratings occurring in circumstances such as direct-on-line starting.

For speeds not shown, calculate the nominal torque for the design application using the formula below and select

**Table 1**

Elements				
Type	Temperature range	Misalignment		Power factor
		Angular	Parallel	
–	°C	°	mm	–
Nitrile	–40 to 100	1	0.38	1
Urethane	–35 to 70	1	0.38	1.5
Hytrel®	–50 to 120	0.5	0.38	3

coupling according to nominal torque ratings.

Nominal torque (Nm) =

$$\frac{\text{Design power (kW)} \times 9\,550}{\text{r/min}}$$

For additional useful information on jaw couplings, such as standard bore and keyway data, please refer to **tables 1** to **3**.

## Order data

A complete jaw coupling consists of: 2 hubs and 1 element. A complete coupling with spacer consists of 2 hubs, 2 nitrile wrap elements, 2 ring kits and 1 spacer.

For more detailed information on ordering specific couplings, refer to **table 4**.

Table 2

## Power ratings – Nitrile elements

Speed	Coupling sizes									
	50	70	75	90	95	100	110	150	190	225
r/min	kW									
50	0.018	0.030	0.06	0.10	0.14	0.3	0.5	0.8	1.1	1.5
100	0.037	0.060	0.12	0.20	0.27	0.6	1.1	1.6	2.1	2.9
200	0.074	0.121	0.25	0.40	0.54	1.2	2.2	3.1	4.2	5.9
300	0.110	0.181	0.37	0.60	0.81	1.7	3.3	4.7	6.3	8.8
400	0.147	0.242	0.50	0.80	1.08	2.3	4.4	6.3	8.4	11.7
500	0.184	0.302	0.62	1.01	1.35	2.9	5.5	7.9	10.5	14.7
600	0.221	0.363	0.75	1.21	1.62	3.5	6.6	9.4	12.6	17.6
700	0.257	0.423	0.87	1.41	1.89	4.1	7.7	11.0	14.7	20.5
720	0.265	0.435	0.90	1.45	1.95	4.2	7.9	11.3	15.1	21.1
800	0.294	0.483	1.00	1.61	2.16	4.6	8.8	12.6	16.8	23.5
900	0.331	0.544	1.12	1.81	2.43	5.2	9.9	14.1	18.8	26.4
960	0.353	0.580	1.20	1.93	2.59	5.6	10.6	15.1	20.1	28.1
1000	0.368	0.604	1.25	2.01	2.70	5.8	11.0	15.7	20.9	29.3
1200	0.441	0.725	1.50	2.41	3.24	7.0	13.2	18.8	25.1	35.2
1400	0.515	0.846	1.74	2.81	3.78	8.1	15.4	22.0	29.3	41.1
1440	0.529	0.870	1.79	2.90	3.89	8.4	15.8	22.6	30.2	42.2
1600	0.588	0.967	1.99	3.22	4.32	9.3	17.6	25.1	33.5	46.9
1800	0.662	1.088	2.24	3.62	4.86	10.4	19.8	28.3	37.7	52.8
2000	0.735	1.208	2.49	4.02	5.40	11.6	22.0	31.4	41.9	58.6
2200	0.809	1.329	2.74	4.42	5.94	12.8	24.2	34.6	46.1	64.5
2400	0.882	1.450	2.99	4.83	6.48	13.9	26.4	37.7	50.3	70.4
2600	0.956	1.571	3.24	5.23	7.02	15.1	28.6	40.8	54.5	76.2
2800	1.029	1.692	3.49	5.63	7.56	16.2	30.8	44.0	58.6	82.1
2880	1.059	1.740	3.59	5.79	7.78	16.7	31.7	45.2	60.3	84.4
3000	1.103	1.813	3.74	6.03	8.10	17.4	33.0	47.1	62.8	88.0
3600	1.323	2.175	4.49	7.24	9.73	20.9	39.6	56.5	75.4	105.5
Nominal torque Nm	3.51	5.77	11.9	19.2	25.8	55.4	105	150	200	280

Table 3

## Standard bore and keyway chart

Bore	Keyway	Coupling size									
		050	070	075	090	095	100	110	150	190	225
mm	mm	-									
9	3×1.4	X	X	X	X	-	-	-	-	-	-
10	3×1.4	X	X	X	X	-	-	-	-	-	-
11	4×1.8	X	X	X	X	-	-	-	-	-	-
12	4×1.8	X	X	X	X	X	-	-	-	-	-
14	5×2.3	X	X	X	X	X	X	-	-	-	-
15	5×2.3	-	X	X	X	X	X	-	-	-	-
16	5×2.3	-	X	X	X	X	X	X	X	-	-
17	5×2.3	-	X	X	X	X	X	X	X	X	-
18	6×2.8	-	X	X	X	X	X	X	X	X	-
19	6×2.8	-	X	X	X	X	X	X	X	X	X
20	6×2.8	-	-	X	X	X	X	X	X	X	-
22	6×2.8	-	-	X	X	X	X	X	X	X	-
24	8×3.3	-	-	-	X	X	X	X	X	X	X
25	8×3.3	-	-	-	-	X	X	X	X	X	X
28	8×3.3	-	-	-	-	X	X	X	X	X	X
30	8×3.3	-	-	-	-	-	X	X	X	X	X
32	10×3.3	-	-	-	-	-	X	X	X	X	X
35	10×3.3	-	-	-	-	-	X	X	X	X	X
38	10×3.3	-	-	-	-	-	X	X	X	X	X
40	12×3.3	-	-	-	-	-	-	X	X	X	X
42	12×3.3	-	-	-	-	-	-	X	X	X	X
45	14×3.8	-	-	-	-	-	-	-	X	X	X
48	14×3.8	-	-	-	-	-	-	-	X	X	X
50	14×3.8	-	-	-	-	-	-	-	-	X	X
55	16×4.3	-	-	-	-	-	-	-	-	X	X
60	18×4.4	-	-	-	-	-	-	-	-	-	X

Table 4

## Order data

Coupling type	Flanges	Qty	Element	Qty	Spacer shaft	Qty	Nitrile wrap element	Qty	Ring kit	Qty
RSB both sides	PHE L095HUB	2	PHE L095NR or PHE L095UR PHE L095HL	1	PHE L090X ... SPACER1		PHE L090NRWRAP	2	PHE L090RINGKIT	2
Bore with keyway/ RSB combination	PHE L095HUB PHE L095 - ... MM	1 1	PHE L095NR or PHE L095UR PHE L095HL	1	PHE L090X ... SPACER1		PHE L090NRWRAP	2	PHE L090RINGKIT	2
Bore with keyway on both sides	PHE L095 - ... MM	2	PHE L095NR or PHE L095UR PHE L095HL	1	PHE L090X ... SPACER1		PHE L090NRWRAP	2	PHE L090RINGKIT	2
Bore only/ RSB combination	PHE L095 - ... MMP PHE L095HUB	1 1	PHE L095NR or PHE L095UR PHE L095HL	1	PHE L090X ... SPACER1		PHE L090NRWRAP	2	PHE L090RINGKIT	2
Bore only	PHE L095 - ... MMP	2	PHE L095NR or PHE L095UR PHE L095HL	1	PHE L090X ... SPACER1		PHE L090NRWRAP	2	PHE L090RINGKIT	2
Bore only/bore with keyway combination	PHE L095 - ... MMP PHE L095 - ... MM	1 1	PHE L095NR or PHE L095UR PHE L095HL	1	PHE L090X ... SPACER1		PHE L090NRWRAP	2	PHE L090RINGKIT	2

NR = Nitrile  
UR = Urethane  
HL = Hytrel

Available spacer shaft lengths are 100 mm and 140 mm. To complete the designation, add spacer length. For example: PHE L090X100SPACER for spacer of 100 mm, coupling size 090.  
When ordering bored to size and keywayed hubs, it is required that the bore diameter is added to the designation found in the table above.  
Where a keyway is NOT required, the designation should be suffixed with a P.  
PHE L150-18MM = Hub Size 150 with 18 mm bore and keyway.  
PHE L070-16MMP = Hub Size 070 with 16 mm bore (no keyway).

# Installation

- 1 Place each coupling on its shaft so that shaft ends do not protrude into the internal section of the coupling (→ fig. 1). Then tighten the set screws.
- 2 Insert the coupling element into one side of the coupling (→ fig. 2).
- 3 Move the other coupling side into position and connect the two halves (→ fig. 3). Check that the assembled length is correct (→ fig. 4).
- 4 Check the angular misalignment by checking the assembled length in four positions at 90° around the coupling. Check parallel misalignment using a straight edge across the length of the coupling flange (→ fig. 5). Allowable angular misalignment for all jaw couplings is 1°. Allowable parallel misalignment for all jaw couplings is 0.38 mm.

**Note:** For most consistent results, check across at least 3 of the 6 points where the rubber elements are visible between the flanges.

Fig. 1



Fig. 2

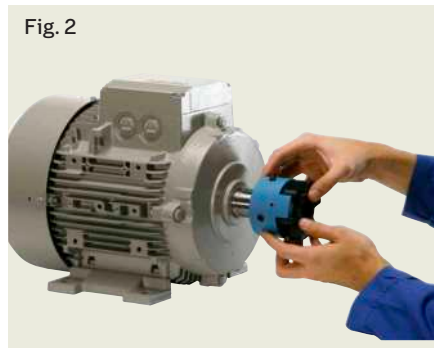

Fig. 3



Fig. 4

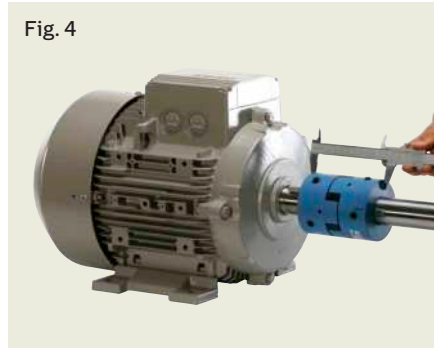
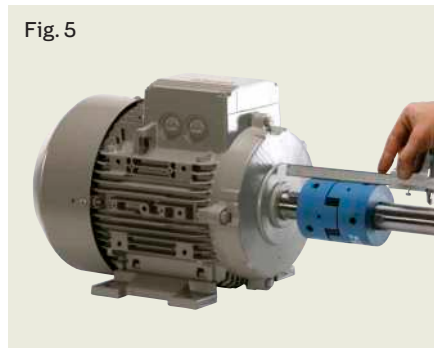
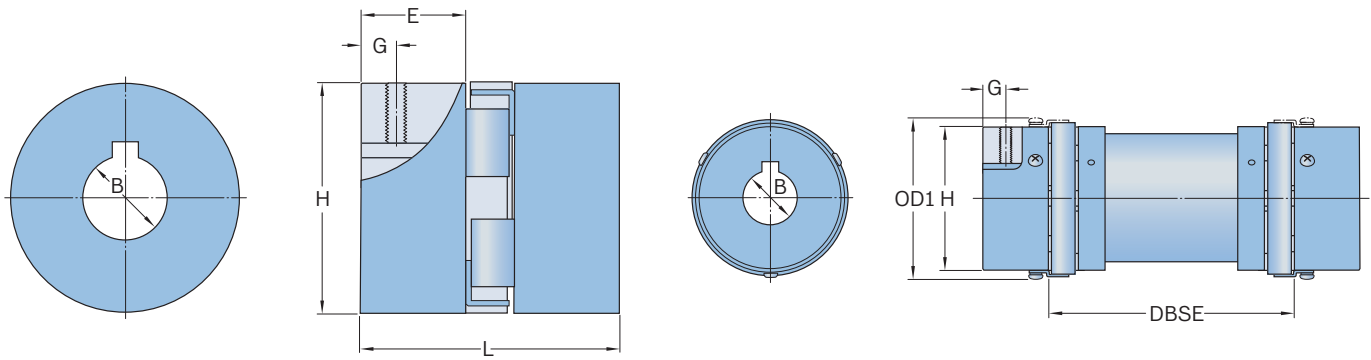

Fig. 5



# SKF Jaw Couplings



Hub

Spacer

Size	Dimensions								Set screw	Approx. mass <sup>2)</sup>	Speed Max.	Designation
	Pilot bore	Max.	OD	OD <sup>1)</sup>	L	E	H	G				
–	mm								–	kg	r/min	–
035	3.20	9.5	15.9	–	20.6	6.7	15.9	–	–	0.03	31 000	PHE L035HUB
050	6.35	14.0	27.5	–	44.0	16.0	27.5	6.5	M6	0.05	18 000	PHE L050HUB
070	9.00	19.0	35.0	–	51.0	19.0	35.0	9.5	M6	0.12	14 000	PHE L070HUB
075	9.00	24.0	44.5	–	54.0	21.0	44.5	9.0	M6	0.22	11 000	PHE L075HUB
090	9.00	24.0	54.0	–	54.0	21.0	54.0	8.7	M6	0.28	9 000	PHE L090HUB
095	9.00	28.0	54.0	64	64.0	25.0	54.0	11.0	M8	0.31	9 000	PHE L095HUB
100	12.70	35.0	65.0	77	89.0	35.0	65.0	11.0	M8	0.75	7 000	PHE L100HUB
110	15.87	42.0	84.0	97	108.0	43.0	84.0	19.0	M10	1.50	5 000	PHE L110HUB
150	15.87	48.0	96.0	112	115.0	45.0	96.0	22.0	M10	2.40	4 000	PHE L150HUB
190	19.05	55.0	115.0	130	133.0	54.0	102.0	22.0	M12	3.50	3 600	PHE L190HUB
225	19.05	60.0	127.0	143	153.0	64.0	108.0	29.0	M12	4.50	3 600	PHE L225HUB

<sup>1)</sup> Outer diameter of ring kit

<sup>2)</sup> Mass of hub with pilot bores

DBSE = Distance between shaft ends

Hub material is high grade cast iron. Spacer material is aluminium.