

# SKF

# FX KEYLESS BUSHINGS

Simple, accurate and reliable shaft installations with a minimum of machining



# Contents

Introduction.....	3
Less machining with more reliability.....	3
Keyways and splines require larger shaft diameters.....	3
Interference fits need close tolerances.....	3
An innovative concentric locking technology.....	3
Nomenclature and principal of operation.....	4
1 Introduction.....	4
2 Principle of operation.....	4
3 Advantages.....	5
4 General notes.....	5
5 ASME shaft and torque formulae.....	6
6 Service factors (Fs).....	6
7 Coefficient of friction ( $\mu F$ ).....	7
Product information.....	8
FX Keyless bushings models.....	10
Additional series and types.....	13
General fitting instructions FX friction locking bushes (excluding Series FX190).....	14
1 Introduction.....	14
2 Installation and maintenance (general notes).....	15
3 Installation.....	15
4 Disassembly.....	15
Product tables.....	16
Mounting instructions for constrictive style shaft-hub locking assemblies (FX190).....	40
1 Introduction.....	40
2 Tolerance guidelines for FX190 series.....	40
3 Installation.....	40
4 Removal.....	41
5 General.....	41
Product tables.....	42

# SKF FX Keyless bushings

## Less machining with more reliability

Mounting components such as gears, couplings and pulleys to a shaft often requires sophisticated broaching or milling techniques of the shaft. With FX Keyless bushings these operations can be done with a minimum amount of machining. This saves time and can significantly reduce production costs, when compared to using traditional connections, such as interference fits, keyways, splines, keyed bushing systems, QD and tapered bushings (fig. 1).

## Keyways and splines require larger shaft diameters

Keys and keyways have been around for quite some time, and keyed tapered bushings are especially popular as the same bushing can be used for different shaft sizes. They are easy to prepare, quick to install and provide a low-cost solution. But they are also surprisingly ineffective. When keyways are cut into components and shafts, they reduce the cross section (fig. 2), and consequently the strength of the machined parts.

Keys and keyways may also require a clearance fit on several planes. The combined effect of these clearances is backlash, which in some cases can enlarge the keyways, while promoting fatigue failure and fretting corrosion.

## Interference fits need close tolerances

Interference fits of the shaft offer advantages like zero backlash and uniform contact pressures but require extended fit lengths and extremely close machining tolerances of shaft and component bore. Maintenance is also often complex, components can seldom be reused, and a press or a heat source might be needed for mounting.

## An innovative concentric locking technology

FX Keyless bushings create an interference fit with uniform contact pressure between shafts and the components that are fixed to the shaft. The near perfect 360-degree grip on shaft and component bore offers true zero backlash installation and eliminates shaft damage and the possibility of fretting corrosion.

As a series of screws or a single hexagonal nut is tightened, two tapered rings are displaced axially. One steel ring expands in the component bore while the other ring contracts evenly around the shaft, giving a true concentric, tight fit. The bushings are easy to adjust axially and radially, and simple to install and remove. Unless damaged they can be reused in most instances.

With FX Keyless bushings, you can easily mount components with a cylindrical (non-tapered) bore to a standard, plain shaft. Reduce shaft size and weight, machining costs, and installation time while improving accuracy and reliability. With 24 different designs, you can find the best bushing solution to your application.

Traditional connections

Fig. 1

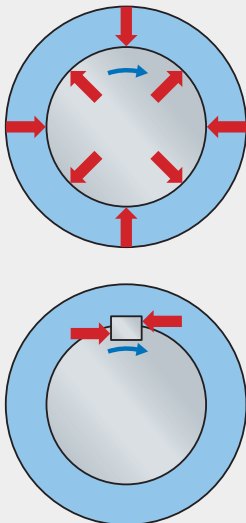
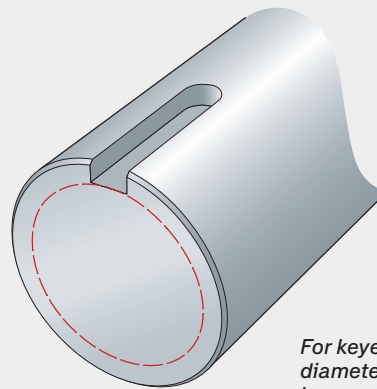

Fig. 2



*For keyed bushings, the shaft diameters need to be increased by approx. 10% to cover the expected weakening caused by the keyways*

# Nomenclature and principal of operation

## 1. Introduction

The friction locking assembly has been available for over 40 years, yet it is still not widely used in the engineering industry, despite its obvious advantages to both the manufacturer and the end-user.

1.1 For hundreds of years the engineers and/or inventors have created a wide array of methods and systems to attach a mechanism or hub to a rotating shaft, with no slip, while still maintaining optimum performance from the resulting connection of both the component and the shaft.

1.1.1 These methods have included:

- Welding/brazing
  - Setscrew/dowelling/roll pin
- Keyseats, according to various international standards such as ISO, DIN, ASME, BS etc including:
  - Parallel
  - Rectangular
  - Gib
- Splines
- Bushing systems, including:
  - Taper bush
  - "QD" Flanged
  - Hydraulic
  - Clamping
- Shrink disc/compressive systems
  - Mechanical and hydraulic

1.1.2 While the above all offer a variety of benefits, depending on the application/installation requirements, e.g. duty, torsional moment, dimensional boundaries, loading (shock, reverse etc.), temperature, environment, they all have a number of limitations.

## 2. Principle of operation

2.1 The friction locking assembly, in its most basic configuration, consists of one or more sets of tapers, (which may vary in included angle, depending on the series, type and duty) being drawn over each other.

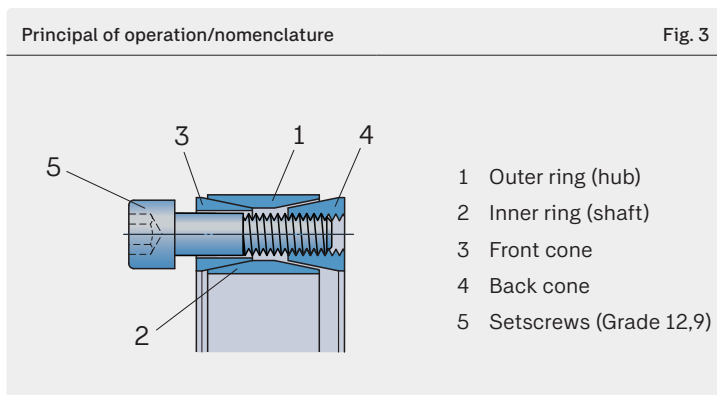

As the cones are drawn together (see fig. 3), the inner and outer rings, which are split, are expanded inward (inner ring) onto the shaft, and outward (outer ring) into the hub or attached device (e.g. sprocket or pulley).

As there are no "stress risers" due to welding, or keyways, the amount of torsion the shaft is capable of transmitting is increased.

Conversely, for a specific value, it may be possible to reduce the shaft diameter required, reducing costs of bearings and shafting, and overall dimensions (see fig. 4a).

## 3. Advantages

- High transmittable torque and axial loads.
- Easy to install and remove.
- High resistance to alternating torque.
- Increased shaft capacity (due to no key seat stresses).
- Zero backlash.
- Easy to adjust/position.
- True running (<0.02 μm possible).
- Re-usable.

$$M_T = N \times \mu \times \frac{d}{2} \quad [\text{Nm}]$$

Where N =  $\pi \times d \times L_1 \times P$  (N)  
 = Radial force exerted by the hub

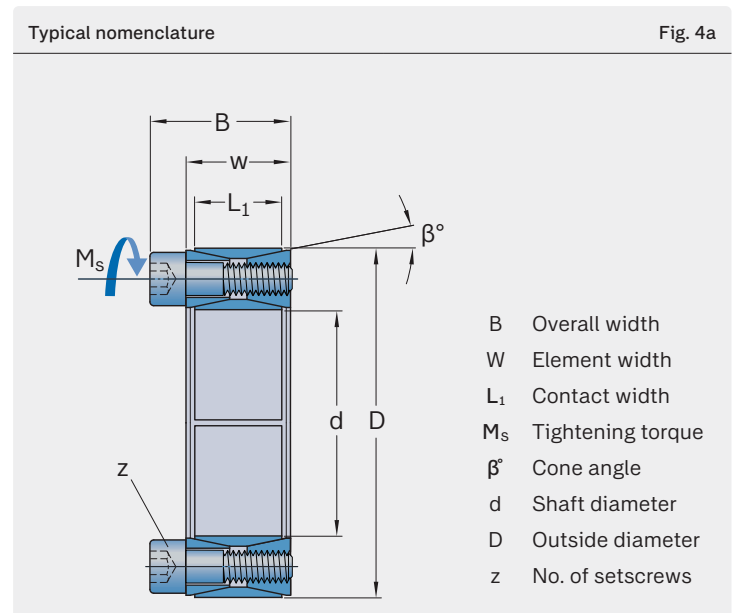

- Self-centering (depending on series).
- Simpler shaft and hub machining (typically H11/h11 ; H8/h8 etc...) and minimum roughness of  $R_T$  16  $\mu\text{m}$ .
- Wide temperature operational range (typically -40 to 150 °C without modification to capacity) (see Section 3.1).
- Ability to accept a relatively wide range of clearances with minimal torsional loss.
- No wear of internal parts.
- Wide range of series available (23 in the SKF "FX" range) to accommodate most applications.
- Overall interchangeability between most manufacturers.
- Available in stainless steel subject to MOQ.
- (Note: Reduced MT capacity).
- The friction locking assembly has been available for over 40 years, but is still not widely used in the engineering industry, despite its obvious advantages to both the manufacturer and the end-user. Not recommended as a principle 'overload' device!.

### 3.1 Temperature effect ( $\Delta_{temp}$ )

Locking assemblies are capable of operating in temperatures up to 300 °C, if:

- The temperature is ambient to all metal components.
- Materials have a similar coefficient of thermal expansion ( $\pi$ ).
- Typical shaft and bore tolerances (e.g. H8/h8) may have to be modified from the standard.

## 4. General notes

4.1 The torque capacity of the friction locking assembly is directly proportional to:

- The contact area of the inner and outer rings of the unit on the shaft and hub respectively, being a function of the face width ( $L_1$ ) and the inner/outer diameters ('d' and 'D').
- The included angle of the ring taper ( $\beta^\circ$ ).  
Note: The smaller this angle, the higher the possible transmissible torque. Angles can range from 12° (low-medium torque capacity/duty) to 5° (heavy duty).
- The number of setscrews ( $z$ ) and their tightening torque ( $M_s$ ).
- The (limiting) strength of both the shaft ( $P$ ) and hub ( $P'$ ) materials ( $\text{N}/\text{mm}^2$ ).

The coefficient of friction ( $\mu$ ) between the conical rings and hub/shaft surfaces, and whether 'dry' ( $\mu=0.14$ ) or 'lubricated' ( $\mu=0.12$ ) mounting (see Section 7).

4.2 Depending on the purpose and application of the locking assembly, a service factor should be applied according to the recommendations in the catalogue. This will depend on the type of prime mover, inertias and torques involved, and any peak and/or reverse loads/cycles.

4.3 It is important the setscrews are tightened correctly (in their correct sequence) and to the torque figures given ( $M_s$ ) to ensure the unit is capable of transmitting its rated torque ( $M_T$ ).

4.4 Locking assemblies will accept limited axial loads ( $F_{Ax}$ ) only, and may have to be de-rated if both torsional ( $M_T$ ) and axial ( $F_{Ax}$ ) loads are present.

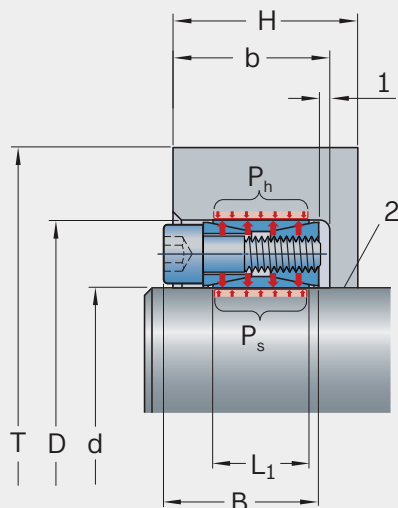

- |       |  |
|-------|--|
| H     | Hub width  |
| b     | Bore recess depth  |
| $P_h$ | Hub stress   |
| $P_s$ | Shaft stress   |
| T     | Hub dia.   |
| D     | Outside diameter   |
| d     | Shaft diameter   |
| $L_1$ | Contact width  |
| B     | Overall width  |
| 1     | Gap at back of assembly<br>(for hubs with centering guide) |
| 2     | Centering guide  |

Fig. 4b

## 5. ASME shaft and torque formulae

5.1 The most common method of calculating shaft diameter, from known values of torsional and bending moment, is the ASME shaft formulae (or corresponding DIN/ISO formulae).

This takes into account the materials' allowable working stress (either keyed or not), the torsional moment, the bending moment (if present) and safety factors for the duty/application.

The full formulae and nomenclature is shown below.

Where

$$D^3 = \frac{16}{\pi \times S_s} \times \sqrt{(K_T \times M_T)^2 + (K_B \times M_B)^2} \quad [\text{mm}]$$

D = Shaft diameter (mm)

$S_s$  = Allowable (safe) stress of steel (see Section 5.1.1)

For keyed commercial steel = 41 MN/m<sup>2</sup> (6 000 psi)

For unkeyed commercial steel = 55 MPa (8 000 psi)

$\pi$  = A constant (3.14159)

$K_T$  = Torsional moment constant;

Minor shock 1.25

Moderate shock 1.50

Heavy shock 1.75

$M_T$  = Torsional moment (Nm) (see Section 5.2)

$K_B$  = Bending moment constant;

Minor shock 1.75

Moderate shock 2.00

Heavy shock 2.50

$M_B$  = Bending moment (Nm) (refer to relevant formulae

for the respective layout, e.g. Machinery Handbook...)

5.1.1 Under the imperial nomenclature the relevant "safe working loads" were commonly assumed at 6 000 psi and 8 000 psi for keyed and unkeyed commercial steels respectively.

While there may be variances in the actual values (and proportional relationships) for other materials, especially high alloys, the basic relationship between keyed and non-keyed shafts still applies.

### Shape factor based on installation setup

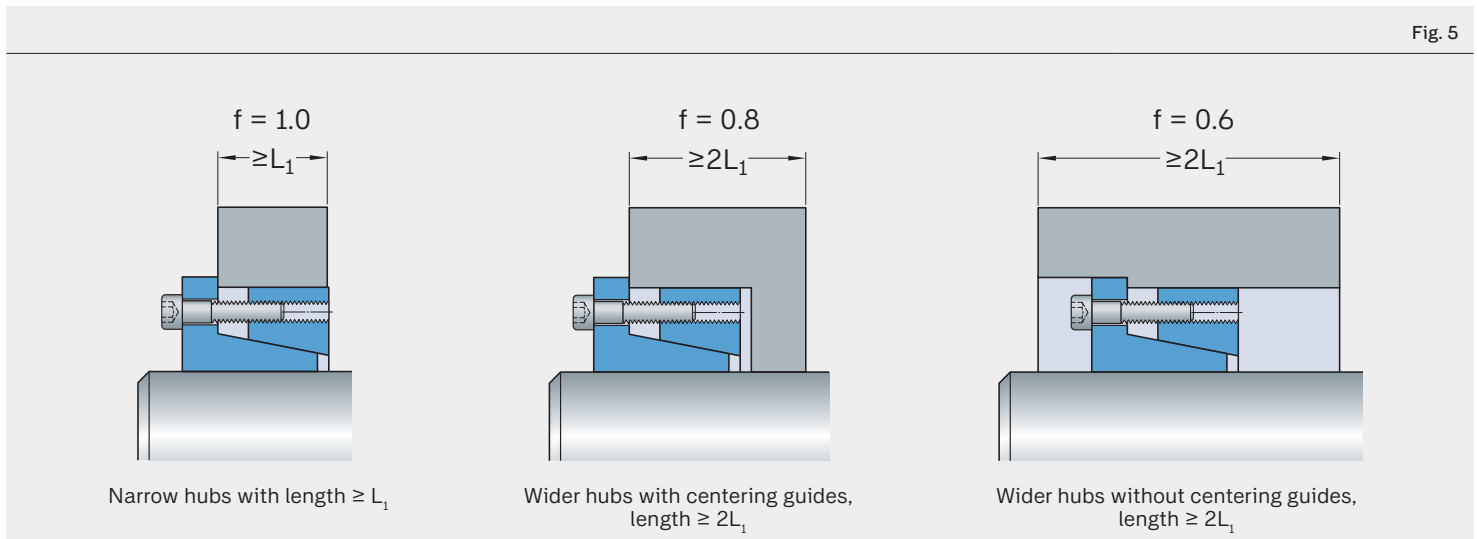

Fig. 5

5.2 To calculate the torsional moment ( $M_T$ ) in the system the basic torque formulae can be used:

### 5.2.1 Torque formulae

Where

$M_T$  = Torque (Moment) [Nm]

kW = Kilowatt [kW]

r/min = Revolutions per minute [ $\text{min}^{-1}$ ]

$$M_T = \frac{\text{kW} \times 9\,550}{\text{r/min}} \quad [\text{Nm}]$$

9 550 A constant, derived from:  $60 \times 10^3 / 2\pi$

$$M_T = \frac{\text{kW} \times 60 \times 10^3}{2 \times \pi \times \text{r/min}} \quad [\text{Nm}]$$

### 5.2.2 Alternatively

5.2.2 The unit (series) capacity should have a capacity equal or greater than

Where

$$M_T = \frac{\text{kW} \times 9\,550}{\text{r/min}} \times F_s \quad [\text{Nm}]$$

$F_s$  = Applicable service factor, dependent on duty and type of prime mover/application (see Section 6).

## 6. Service factors ( $F_s$ )

6.1 Before selecting the locking assembly, it is necessary to establish the duty and apply the relevant service factor.

6.1.1 Typical service factor guidelines are shown in Table 1 below, determined by:

- Prime mover (e.g. electric motor, I.C. engine, turbine etc.)
- Duty (hours/day) and cycles
- Application
- Any peak/fluctuating or reverse torques

## 7. Coefficient of friction ( $\mu_f$ )

As mentioned in section 4.1, the coefficient of friction, between the mating surfaces can have a significant effect on the operating capacity of the locking assembly. While in most power transmission applications (such as bearings and gearing), the friction coefficient is required to be as low as possible, the simple principle of the locking system relies on friction. It is important to understand this when looking at different manufacturers' catalogue ratings, and the capacities of various sizes to transmit torque.

In fig. 6, the red/yellow cross indicates the friction between the hub/shaft and locking assembly inner and outer rings. The green crosses indicate the friction internally, between the inner/outer rings and the tightening cones. These internal contact faces may be lightly lubricated during assembly, to allow the surfaces to slide over each other. The typical coefficient of  $\mu = 0.12$  usually determines the catalogue rating ( $M_r$ ).

A typical "DRY" connection between the cone faces, (as must always be the case on the inner and outer rings) will generally give a slightly increased coefficient of  $\mu = 0.14$ . i.e. the catalogue value may be increased by approx. 16%.

Additionally, the coefficient of friction ( $\mu_f$ ) may also be affected by the specific materials in contact.

7.1 The table below shows some typical values for the coefficient of friction ( $\mu_f$ ).

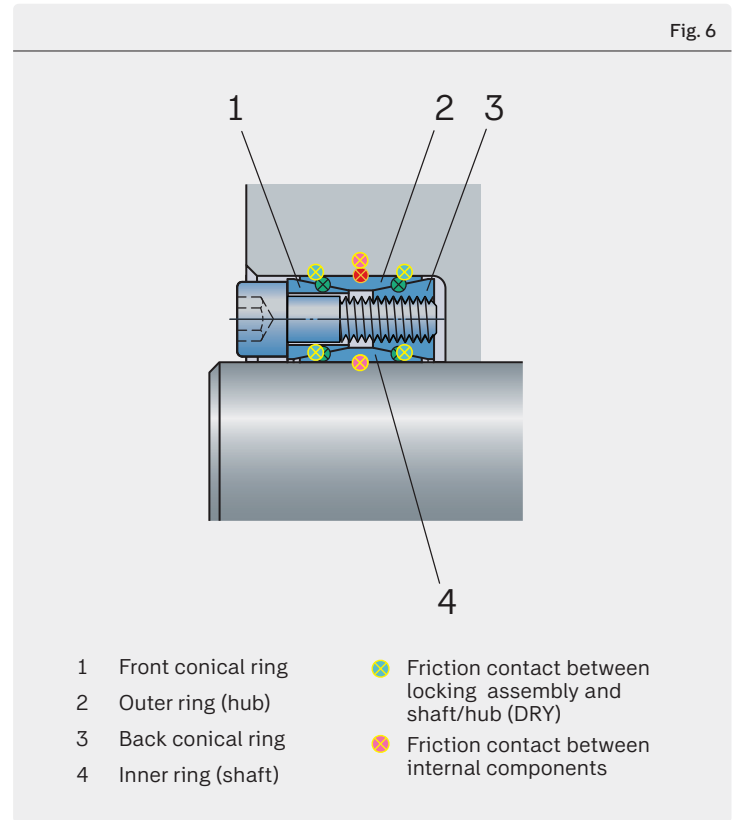

Table 1

Service factor (fs)	Type of load on machine (element)		
	Group I Even loads	Group II Moderate shock	Group III Heavy shock
	Typical Examples		
Prime mover (Driver)	Electric generators Centrifugal pumps Fans Light duty belt conveyors Turbo-compressors Agitators	Piston compressors Small piston pumps Machine tools Packaging machines Woodworking/joinery machines Non-uniformly loaded conveyors (Belt, chain) Elevators	Large piston pumps Presses and punching machines Draw benches Metals machines Frequently activated/loaded tools (pneumatic)
Electric motors turbines	1.00–1.25	1.25–1.5	1.5–1.75
Multi-cylinder piston engines	1.25–1.50	1.50–1.75	1.75–2.00
Single cylinder piston engines	1.75–2.00	2.00–2.25	2.25–3.00

Table 2

Typical coefficients of friction ( $\mu_f$ )

Material	Surface condition	Coefficient of friction ( $\mu_f$ )
Steel on steel	Thin film of oil	0.12 <sup>2)</sup>
Steel on steel	Dry (non-solvent)	0.14
Steel on steel	Cleaned with solvent	0.17
Steel on stainless steel	Thin film of oil	0.10
Steel on stainless steel	Cleaned with solvent	0.15
Cast iron	Dry (non-solvent)	0.15
Aluminium (non durals <sup>1)</sup> )	Dry (non-solvent)	0.15

Table 3

Hub surface pressure $P_N$	Shape factor	Material yield stress $\sigma_{0.2}$ [N/mm <sup>2</sup> ] for typical materials													
		Cast irons			Carbon steels		Alloy/Heat treatable steels					Gear steels			
		GG20	GG25 HT250	GG30 304.	ST37-2 GS45	GGG40 GS52 C22 316	1035 C35	GGG50 ST60-2 C40	ST70-2 1045 420	C60 GS70		EN19A	42CrMo4 4140(H)	EN36A	4340
$\sigma = 150$	$\sigma = 180$	$\sigma = 200$	$\sigma = 220$	$\sigma = 250$	$\sigma = 280$	$\sigma = 300$	$\sigma = 350$	$\sigma = 400$	$\sigma = 450$	$\sigma = 480$	$\sigma = 500$	$\sigma = 550$	$\sigma = 600$		
N/mm <sup>2</sup> –															
60	0.6	1.28	1.25	1.20	1.18	1.16	1.14	1.12	1.11	1.09	1.08	1.08	1.08	1.07	1.06
	0.8	1.39	1.30	1.24	1.23	1.23	1.21	1.18	1.15	1.12	1.11	1.11	1.10	1.09	1.08
	1.0	1.55	1.42	1.38	1.32	1.29	1.26	1.22	1.19	1.16	1.14	1.14	1.13	1.12	1.10
65	0.6	1.30	1.25	1.22	1.20	1.19	1.16	1.13	1.12	1.10	1.09	1.09	1.09	1.08	1.07
	0.8	1.44	1.35	1.30	1.28	1.20	1.20	1.20	1.17	1.14	1.12	1.12	1.12	1.10	1.09
	1.0	1.60	1.45	1.40	1.35	1.31	1.28	1.24	1.21	1.18	1.16	1.16	1.15	1.14	1.12
70	0.6	1.34	1.26	1.24	1.22	1.19	1.17	1.15	1.13	1.11	1.10	1.10	1.09	1.08	1.07
	0.8	1.48	1.38	1.34	1.30	1.26	1.23	1.20	1.18	1.15	1.13	1.13	1.13	1.11	1.10
	1.0	1.65	1.50	1.45	1.40	1.35	1.31	1.26	1.23	1.20	1.17	1.17	1.17	1.15	1.13
75	0.6	1.30	1.28	1.25	1.23	1.21	1.19	1.16	1.14	1.12	1.11	1.11	1.10	1.09	1.08
	0.8	1.52	1.42	1.36	1.32	1.29	1.26	1.22	1.19	1.16	1.14	1.14	1.14	1.12	1.11
	1.0	1.74	1.55	1.48	1.42	1.37	1.34	1.30	1.25	1.2	1.18	1.18	1.17	1.15	1.13
80	0.6	1.39	1.31	1.28	1.25	1.22	1.20	1.18	1.16	1.13	1.11	1.11	1.11	1.09	1.08
	0.8	1.58	1.45	1.39	1.35	1.31	1.28	1.24	1.21	1.18	1.15	1.15	1.15	1.13	1.11
	1.0	1.81	1.61	1.53	1.46	1.40	1.36	1.31	1.27	1.22	1.20	1.20	1.18	1.16	1.14
85	0.6	1.42	1.34	1.30	1.27	1.24	1.22	1.19	1.17	1.14	1.12	1.12	1.12	1.10	1.09
	0.8	1.53	1.49	1.42	1.38	1.33	1.30	1.26	1.23	1.19	1.16	1.16	1.16	1.14	1.12
	1.0	1.90	1.67	1.57	1.50	1.43	1.39	1.34	1.29	1.24	1.21	1.21	1.20	1.17	1.15
90	0.6	1.46	1.36	1.32	1.28	1.26	1.23	1.20	1.18	1.15	1.13	1.13	1.12	1.11	1.09
	0.8	1.69	1.53	1.46	1.40	1.35	1.32	1.28	1.24	1.20	1.18	1.18	1.17	1.15	1.13
	1.0	2.00	1.73	1.62	1.54	1.47	1.42	1.36	1.31	1.26	1.22	1.22	1.21	1.19	1.16
95	0.6	1.49	1.39	1.34	1.30	1.27	1.24	1.21	1.18	1.15	1.14	1.14	1.13	1.11	1.10
	0.8	1.75	1.57	1.49	1.43	1.38	1.34	1.30	1.26	1.21	1.19	1.19	1.18	1.16	1.14
	1.0	2.11	1.80	1.68	1.59	1.50	1.45	1.39	1.33	1.27	1.24	1.24	1.22	1.20	1.17
100	0.6	1.53	1.41	1.36	1.32	1.29	1.24	1.22	1.19	1.16	1.14	1.13	1.13	1.12	1.11
	0.8	1.81	1.61	1.53	1.46	1.40	1.34	1.31	1.27	1.22	1.20	1.18	1.18	1.16	1.14
	1.0	2.24	1.87	1.73	1.63	1.54	1.45	1.41	1.35	1.29	1.25	1.24	1.22	1.20	1.18
105	0.6	1.56	1.44	1.39	1.34	1.30	1.26	1.24	1.21	1.17	1.15	1.14	1.14	1.12	1.11
	0.8	1.88	1.66	1.56	1.50	1.43	1.36	1.33	1.29	1.24	1.21	1.19	1.19	1.17	1.15
	1.0	2.38	1.95	1.79	1.68	1.57	1.48	1.44	1.38	1.31	1.27	1.25	1.24	1.21	1.19
110	0.6	1.60	1.47	1.41	1.36	1.32	1.27	1.25	1.21	1.16	1.16	1.14	1.14	1.13	1.12
	0.8	1.96	1.71	1.60	1.53	1.45	1.38	1.35	1.30	1.25	1.22	1.19	1.19	1.18	1.16
	1.0	2.55	2.04	1.86	1.73	1.61	1.51	1.47	1.40	1.33	1.28	1.25	1.25	1.23	1.20
115	0.6	1.64	1.50	1.43	1.36	1.34	1.29	1.26	1.23	1.19	1.17	1.15	1.15	1.14	1.12
	0.8	2.04	1.76	1.64	1.56	1.48	1.41	1.37	1.32	1.26	1.23	1.20	1.20	1.19	1.17
	1.0	2.75	2.13	1.93	1.79	1.65	1.55	1.50	1.42	1.34	1.30	1.27	1.27	1.24	1.21

Table 3

Hub surface pressure $P_N$	Shape factor	Material yield stress $\sigma_{0.2}$ [N/mm <sup>2</sup> ] for typical materials													
		Cast irons			Carbon steels			Alloy/Heat treatable steels				Gear steels			
		GG20 $\sigma = 150$	GG25 HT250 $\sigma = 180$	GG30 304. $\sigma = 200$	ST37-2 GS45 $\sigma = 220$	GGG40 GS52 C22 316 $\sigma = 250$	1035 C35 $\sigma = 280$	GGG50 ST60-2 C40 $\sigma = 300$	ST70-2 1045 420 $\sigma = 350$	C60 GS70 $\sigma = 400$	$\sigma = 450$	EN19A $\sigma = 480$	42CrMo4 4140(H) $\sigma = 500$	EN36A $\sigma = 550$	4340 $\sigma = 600$
N/mm <sup>2</sup> –															
120	0.6	1.69	1.53	1.46	1.40	1.35	1.30	1.28	1.24	1.2	1.18	1.16	1.16	1.15	1.13
	0.8	2.13	1.81	1.69	1.60	1.51	1.43	1.39	1.34	1.28	1.24	1.21	1.21	1.20	1.18
	1.0	3.00	2.24	2.00	1.84	1.70	1.58	1.53	1.45	1.36	1.31	1.29	1.28	1.25	1.22
125	0.6	1.73	1.56	1.40	1.43	1.37	1.32	1.29	1.25	1.21	1.18	1.17	1.17	1.15	1.13
	0.8	2.24	1.87	1.73	1.63	1.54	1.46	1.41	1.35	1.29	1.25	1.23	1.23	1.20	1.18
	1.0	3.32	2.35	2.08	1.91	1.74	1.62	1.56	1.47	1.38	1.33	1.31	1.29	1.27	1.24
130	0.6	1.78	1.59	1.51	1.45	1.39	1.33	1.30	1.26	1.22	1.19	1.18	1.17	1.16	1.14
	0.8	2.35	1.93	1.78	1.67	1.57	1.48	1.44	1.37	1.30	1.27	1.25	1.24	1.22	1.19
	1.0	3.74	2.49	2.17	1.97	1.79	1.65	1.59	1.50	1.40	1.35	1.32	1.30	1.28	1.25
135	0.6	1.83	1.62	1.54	1.47	1.41	1.35	1.32	1.28	1.23	1.20	1.19	1.18	1.16	1.15
	0.8	2.48	2.00	1.83	1.71	1.60	1.51	1.46	1.39	1.32	1.28	1.26	1.25	1.23	1.20
	1.0	4.36	2.65	2.27	2.04	1.84	1.69	1.62	1.52	1.42	1.36	1.34	1.32	1.29	1.26
140	0.6	1.88	1.66	1.56	1.50	1.43	1.36	1.33	1.29	1.24	1.21	1.19	1.18	1.17	1.15
	0.8	2.63	2.07	1.88	1.75	1.63	1.53	1.48	1.41	1.33	1.29	1.27	1.26	1.24	1.21
	1.0	5.39	2.83	2.38	2.12	1.89	1.73	1.66	1.55	1.44	1.38	1.35	1.33	1.30	1.27
145	0.6	1.94	1.69	1.59	1.52	1.45	1.38	1.35	1.30	1.25	1.22	1.20	1.19	1.18	1.16
	0.8	2.80	2.15	1.94	1.80	1.66	1.56	1.50	1.43	1.35	1.30	1.28	1.27	1.25	1.22
	1.0	7.68	3.05	2.50	2.21	1.95	1.78	1.69	1.58	1.46	1.40	1.37	1.35	1.31	1.28
150	0.6	2.00	1.73	1.62	1.54	1.47	1.40	1.36	1.31	1.26	1.23	1.21	1.20	1.18	1.16
	0.8	3.00	2.24	2.00	1.84	1.70	1.58	1.53	1.45	1.36	1.31	1.29	1.28	1.26	1.23
	1.0	-	3.32	2.65	2.30	2.01	1.82	1.73	1.61	1.48	1.41	1.38	1.36	1.33	1.29
155	0.6	2.06	1.77	1.65	1.57	1.49	1.42	1.38	1.33	1.27	1.24	1.22	1.21	1.19	1.17
	0.8	3.25	2.33	2.06	1.89	1.73	1.61	1.55	1.47	1.38	1.33	1.30	1.29	1.26	1.23
	1.0	-	3.66	2.80	2.40	2.07	1.87	1.77	1.64	1.51	1.43	1.40	1.38	1.34	1.30
160	0.6	2.13	1.81	1.68	1.60	1.51	1.43	1.39	1.34	1.28	1.24	1.22	1.21	1.20	1.18
	0.8	3.55	2.43	2.13	1.94	1.77	1.64	1.58	1.49	1.39	1.34	1.31	1.30	1.27	1.24
	1.0	-	4.12	3.00	2.52	2.14	1.91	1.81	1.67	1.53	1.45	1.41	1.39	1.35	1.31
165	0.6	2.21	1.86	1.72	1.62	1.53	1.45	1.41	1.35	1.29	1.25	1.34	1.22	1.20	1.18
	0.8	3.96	2.55	2.21	2.00	1.81	1.67	1.60	1.51	1.41	1.35	1.33	1.31	1.28	1.25
	1.0	-	4.80	3.23	2.65	2.22	1.97	1.86	1.71	1.55	1.47	1.43	1.41	1.37	1.33
170	0.6	2.29	1.90	1.76	1.65	1.55	1.46	1.43	1.37	1.30	1.26	1.45	1.23	1.21	1.18
	0.8	4.52	2.68	2.29	2.06	1.85	1.70	1.62	1.53	1.43	1.36	1.34	1.32	1.29	1.26
	1.0	-	5.92	3.46	2.79	2.30	2.02	1.91	1.74	1.57	1.49	1.45	1.42	1.39	1.35

## FX Keyless bushings models



### FX 10

- Not self-centering (guide recommended).
- Range from 20–900 mm (larger sizes on request). Narrow width (depth).
- Medium torque capability.
- Moderate hub stresses (Pn).
- Self-releasing.
- No axial movement during tightening.



### FX 41

- Limited self-centering capability (compared FX40).
- Range from 20–200 mm (larger sizes on request).
- Narrow width (depth) than FX40.
- Medium torque capability.
- Axial movement while tightening.
- Moderate hub stresses (Pn).



### FX 20

- Self-centering.
- Limited range from 20–130 mm.
- Small outside diameter (but longer).
- Medium torque capability.
- Low-moderate hub stresses.
- No axial movement while tightening.



### FX 50

- Self-centering.
- Expansive design.
- Limited range from 20–140 mm.
- Narrow width (depth).
- Low-medium torque capability.
- Low hub stresses (Pn).



### FX30/FX 31

- Not self-centering (element rings only).
- Range from 6–540 mm.
- Small profile.
- Light torque capability.
- Low hub stresses (Pn).
- May be used in multiple series.
- Additional thrust ring/cap required.
- Outer/inner rings slotted for FX31.



### FX 51

- Self-centering.
- Range from 20–200 mm in standard range.
- Available up to 400 mm (subject to MOQ).
- Medium torque capability
- No axial movement while tightening.
- Moderate-high hub stresses (Pn).



### FX 40

- Self-centering.
- Limited range from 20–140 mm.
- Medium torque capability.
- Axial movement while tightening.
- Moderate hub stresses (Pn).



### FX 52

- Limited self-centering .
- Limited range from 14–50 mm.
- Low-medium torque capability.
- No axial movement.
- Narrower than the FX51 (lower capacity).
- Moderate hub stresses (Pn).



### FX 60

- Excellent self-centering.
- Range from 25–400 mm in standard range.
- One piece center ring and outer sleeve.
- Larger sizes available on request (subject to MOQ).
- High-heavy torque capability.
- Axial movement while tightening.
- Low-moderate hub stresses (Pn).
- See also FX61 and FX400.
- No inner sleeve. The taper rings mount directly on shaft.



### FX 61

- Same characteristics and capacity as the FX60.
- Two piece center ring and outer sleeve.
- Range from 25–400 mm.
- Axial movement while tightening.
- Self-locking.
- Cost factor  $\leq 4.65$ .
- Same dimensions as FX60 and FX400.
- No inner sleeve. The taper rings mount directly on shaft.



### FX 65

- Similar in diameters to FX60, FX61, FX400 series.
- Narrow width series. Available from 100 to 500 mm bore (larger sizes and “inch” bores available on request, subject to MOQ).
- Two piece outer ring.
- One piece inner sleeve.
- Accepts greater bending moment (MB) than standard one piece outer ring constructions (torsional capacity is reduced).
- No axial movement during setscrew tightening.



### FX 80

- Self-centering.
- Expansive design.
- Limited range from 14–70 mm.
- Light duty applications.
- Low torque capability.
- Low hub stresses.
- C spanner nut only, therefore fast mounting.



### FX 90

- Self-centering.
- Longer (L3) version of the FX80.
- Limited range from 14–60 mm.
- Light duty applications.
- Low torque capability.
- Low hub stresses.
- C spanner nut only, therefore fast mounting.



### FX 120

- Not self-centering.
- Expansive design.
- Limited range from 18–80 mm.
- Light duty applications.
- Low torque capability.
- Low hub stresses.
- Fewer setscrews for faster mounting.



### FX 130

- Rigid coupling.
- Constrictive design.
- Same or differing shaft diameters possible.
- Zero backlash.
- Compact.
- Ease of Installation.
- Low to medium torque capacity.
- Limited shaft capacity, 70–80 mm.

## FX Keyless bushings models



### FX 140

- Limited self-centering
- Range from 18–90 mm
- Light-medium torque capability
- No axial movement
- Reduced length (L3)
- Moderate-high hub stresses (Pn)



### FX 190

- Shrink disc (3 series)
- Constrictive design
- Range from 20–200 mm in standard range
- Heavy duty. Very high torque
- No axial movement
- High shaft stresses (PW)
- Cost factor 1.65



### FX 350

- Self-centering
- Range from 10–25 mm
- Low torque capability
- No axial movement
- Narrow face width (L3)
- Low-moderate hub stresses (Pn)



### FX 400

- Self-centering
- Range from 30–400 mm
- Has an inner and outer sleeve
- With loose center ring in contact with both inner and outer sleeve.
- High torque capability
- No axial movement
- Same dimensions as FX60 and FX61
- Low-moderate hub stresses (Pn)

## Additional series and types



### FX 75

- Self-centering.
- Low torque capacity.
- Self-locking.
- Limited bore range, 4–20 mm.
- Axial movement during tightening.
- Available in stainless steel (on request).
- Series is subject to MOQ.

### IN ALL SERIES

- Surface roughness Ra. (max) 12.5 µm.
- Typical tolerances:
  - H8 (bore).
  - h8 (Shaft).
- Setscrews are Grade 12.9 acc. to DIN912 (except FX80, FX90 and FX75).
- Imperial (inch) dimensions, bore only, are available for most sizes, (may be subject to MOQ). All other dimensions remain metric.
- Where “cost factors” are given, these are indicative only, and are relative to the same bore size for Series FX10.

### NOTE

These may be subject to minimum order quantities (MOQ). Please refer to SKF for details.

### IMPORTANT

In the larger heavy duty series (e.g. FX6x.x etc.) the size and the number of setscrews may vary from that of the competitors.

# General fitting instructions

## FX friction locking bushes (excluding Series FX190)

### 1. Introduction

The FX bushing allows the transmission of torque, without the use of keyways, based on the pressure and friction of the connecting inner and outer diameters. For correct operation and safety, it is important correct mounting procedures are followed.

The values shown in the FX Bushing catalogue are based on a coefficient of friction ( $\mu_f$ ) of 0.12, and all surfaces being clean and free from oil and other contaminants.

The use of silicon or "Moly" based products is not recommended.

The torque (and axial) ratings given are based on correct dimensioning of the hub diameters, surface finishes, bore tolerances and the tightening of the setscrews to the correct torque, and in the correct sequence.

- Recommended surface finish:  $R_a \leq 3.2 \mu m$

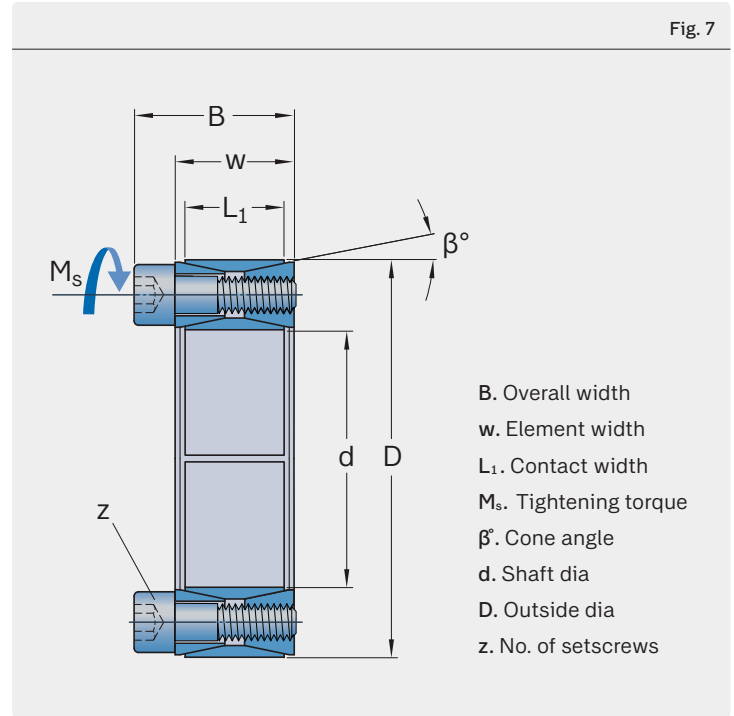

Table 4

Hub and bore tolerances (acc. to ISO 286-2; DIN7157; ANSI B4.2)

Series	FX10	FX20	FX40/41	FX50/51	FX60/61	FX80/90	FX120	FX350	FX400
Bore	H11	H8	H8	H8	H8	H8	H8	H8	H8
Hub	h11	h8	h8	h8	h8	h8	h8	h8	h8

Table 5

Typical coefficients of friction ( $\mu_f$ )

Material	Surface condition	Coefficient of friction ( $\mu_f$ )
Steel on steel	Thin film of oil	0.12 <sup>2)</sup>
Steel on steel	Dry (non-solvent)	0.14
Steel on steel	Cleaned with solvent	0.17
Steel on stainless steel	Thin film of oil	0.10
Steel on stainless steel	Cleaned with solvent	0.15
Cast iron	Dry (non-solvent)	0.15
Aluminium (non durals <sup>1)</sup> )	Dry (non-solvent)	0.15

<sup>1)</sup> High grade aluminium alloy

<sup>2)</sup> Use as catalogue value, unless given otherwise

## 2. Installation and maintenance (general notes)

- 2.1 There are several points that are critical in the bushings correct installation, regardless of the series.
- 2.1.1 The surface roughness ( $R_t$ ) should be no less than  $16\mu\text{m}$  (a higher surface finish - down to  $3.2\mu\text{m}$  - for high capacity units is better).
- 2.1.2 Shaft and hub (bore) tolerances should be adhered to  
Note: modification of these tolerances may be necessary at higher temperatures - e.g. over  $150\text{ }^\circ\text{C}$ .
- 2.1.3 The setscrews (all Grade 12.9) must be tightened to no less than the torque tightening figures in the catalogue, and ALL to the same value (MS), for the FX bushing to be able to transmit the torque value indicated in the catalogue tables.
- 2.1.4 The sequence for tightening the setscrews, should be in a diametrically opposing sequence as illustrated below (typical) in fig. 8.
- 2.1.5 Ensure the (zinc) plated capscrews (where applicable) are positioned in the correct holes - indicating the position of the tapped holes on the front ring (required for removal procedure).

## 3. Installation

Note: The FX bushing will usually be supplied in a carton package (depending on size) and will be protected with an anti-rust lubricant, wrapped in either oil paper and/or a plastic bag for protection from rust, dust and other contaminants. Only remove when ready to install.

- 3.1 Ensure the bushing is free of all contaminant and residual rust protection.
- 3.2 Lightly oil the contact surfaces, removing any excess.
- 3.2.1 Lightly oil the setscrews if necessary.  
Caution: Do not use lubricant with silicon or molybdenum disulphide additives.
- 3.3 Clean the bore and shaft.
- 3.4 Slide the locking assembly into the hub bore.
- 3.4.1 Insert the shaft into the bushing assembly.
- 3.5 For Series FX10, insert the plated setscrews into the front ring holes that are tapped and lightly tighten.
- 3.6 Insert and lightly tighten all other setscrews, ensuring the assembly is in the correct axial position.
- 3.7 The setscrews need to be tightened in a diametral sequence, typically as shown in the diagram below.

- 3.8 Using a torque wrench, the setscrews should be gradually and sequentially torqued to the value (MS) shown in the catalogue, (or from the tables shown for the relevant size).
- 3.9 If the mounting is "dry", the value "MS2" in table 6 should be used.

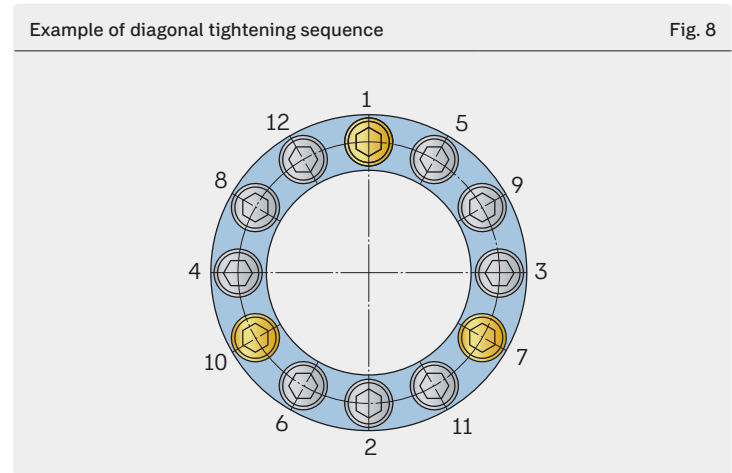

## 4. Disassembly

- 4.1 The loosening of all the setscrews will usually release the FX bushing.
- 4.2 For the units with plated setscrews, (e.g. FX10), these can be completely removed, and a setscrew of the next size up can be inserted and tightened. This will release the front and back element.
- 4.3 For other series, the setscrew may be removed and inserted into the front ring tapped holes. Tightening these will separate the two front and back rings, if required.
- 4.4 With correct installation and disassembly procedures, with no damage, the locking assembly can be re-used indefinitely.

### NOTE

As with all mechanical products, best practice with regards to safety and installation should always be used, with any site procedures and/or standards taking precedence.

Table 6

Tightening torques (Md) (acc. to DIN912); Grade 12.9

Thread $\varnothing$ Tr	M5	M6	M8	M10	M12	M14	M16	M18	M20	M22	M24	M27	M30
$M_s$ $\mu_t = 0.12$	9.8	17	41	83	145	230	355	485	690	930	1 187	1 766	2 354
$M_{s2}$ $\mu_t = 0.14$	10.5	16	39	77	135	215	330	455	650	870	1 110	1 650	2 200

# FX10

d14–800 mm

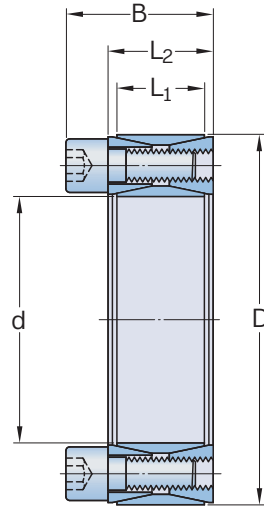

Dimensions					Performance		Pressure		Clamp screws		Weight	Designation	
d	D	L <sub>1</sub>	L <sub>2</sub>	B	Transmissible axial force F <sub>t</sub>	Transmissible torque M <sub>t</sub>	Shaft surface P <sub>w</sub>	Hub surface P <sub>n</sub>	Qty	Size	Tightening torque M <sub>s</sub>	kg	
mm					kN	Nm	N/mm <sup>2</sup>	N/mm <sup>2</sup>	–	–	Nm	kg	–
14	42	17	20	26	26	180	291	97	8	M6	17	0.18	PHF FX10-14X42
15	42	17	20	26	27	200	292	101	8	M6	17	0.18	PHF FX10-15X42
16	44	17	20	26	26	205	251	99	8	M6	17	0.18	PHF FX10-16X44
17	44	17	20	26	33	220	305	110	8	M6	17	0.22	PHF FX10-17X44
18	47	17	20	26	33	230	290	110	8	M6	17	0.22	PHF FX10-18X47
19	47	17	20	26	33	270	275	110	8	M6	17	0.22	PHF FX10-19X47
20	47	17	20	27.5	27	240	210	90	8	M6	15	0.2	PHF FX10-20X47
22	47	17	20	27.5	27	300	195	90	8	M6	15	0.2	PHF FX10-22X47
24	50	17	20	27.5	30	360	195	95	8	M6	15	0.3	PHF FX10-24X50
25	50	17	20	27.5	30	380	190	95	8	M6	15	0.3	PHF FX10-25X50
28	55	17	20	27.5	33	470	185	95	10	M6	15	0.3	PHF FX10-28X55
30	55	17	20	27.5	33	500	175	95	10	M6	15	0.3	PHF FX10-30X55
32	60	17	20	27.5	40	630	192	105	12	M6	15	0.3	PHF FX10-32X60
35	60	17	20	27.5	40	700	180	105	12	M6	15	0.3	PHF FX10-35X60
38	65	17	20	27.5	46	870	188	110	14	M6	15	0.4	PHF FX10-38X65
40	65	17	20	27.5	46	920	180	110	14	M6	15	0.3	PHF FX10-40X65
42	75	20	24	33.5	72	1 500	226	125	12	M8	37	0.6	PHF FX10-42X75
45	75	20	24	33.5	72	1 610	210	125	12	M8	37	0.6	PHF FX10-45X75
48	80	20	24	33.5	71	1 700	196	115	12	M8	37	0.6	PHF FX10-48X80
50	80	20	24	33.5	71	1 770	190	115	12	M8	37	0.6	PHF FX10-50X80
55	85	20	24	33.5	83	2 270	200	130	14	M8	37	0.6	PHF FX10-55X85
60	90	20	24	33.5	83	2 470	180	120	14	M8	37	0.7	PHF FX10-60X90
65	95	20	24	33.5	93	3 040	190	130	16	M8	37	0.7	PHF FX10-65X95
70	110	24	28	39.5	132	4 600	210	130	14	M10	70	1.3	PHF FX10-70X110
75	115	24	28	39.5	131	4 900	195	125	14	M10	70	1.3	PHF FX10-75X115
80	120	24	28	39.5	131	5 200	180	120	14	M10	70	1.4	PHF FX10-80X120
85	125	24	28	39.5	148	6 300	195	130	16	M10	70	1.4	PHF FX10-85X125
90	130	24	28	39.5	147	6 600	180	125	16	M10	70	1.5	PHF FX10-90X130
95	135	24	28	39.5	167	7 900	195	135	18	M10	70	1.6	PHF FX10-95X135
100	145	26	33	47	192	9 600	195	135	14	M12	127	2.2	PHF FX10-100X145
110	155	26	33	47	191	10 500	180	125	14	M12	127	2.5	PHF FX10-110X155
120	165	26	33	47	218	13 100	185	135	16	M12	127	2.6	PHF FX10-120X165
130	180	34	38	52	272	17 600	165	115	20	M12	127	3.8	PHF FX10-130X180
140	190	34	38	52	298	20 900	165	125	22	M12	127	3.9	PHF FX10-140X190
150	200	34	38	52	324	24 200	170	125	24	M12	127	4.0	PHF FX10-150X200
160	210	34	38	52	350	28 000	170	130	26	M12	127	4.3	PHF FX10-160X210
170	225	38	44	60	386	32 800	160	120	22	M14	195	5.8	PHF FX10-170X225
180	235	38	44	60	420	37 800	165	125	24	M14	195	6.0	PHF FX10-180X235
190	250	46	52	68	490	46 500	150	115	28	M14	195	8.5	PHF FX10-190X250
200	260	46	52	68	525	52 500	150	115	30	M14	195	8.6	PHF FX10-200X260

Dimensions					Performance	Transmissible	Pressure	Clamp screws		Weight	Designation		
d	D	L <sub>1</sub>	L <sub>2</sub>	B	Transmissible axial force F <sub>t</sub>	torque M <sub>t</sub>	Shaft surface P <sub>w</sub>	Hub surface P <sub>n</sub>	Qty	Size	Tightening torque M <sub>s</sub>	kg	
mm					kN	Nm	N/mm <sup>2</sup>	N/mm <sup>2</sup>	–	–	Nm	kg	–
220	285	50	56	74	620	68 000	150	115	26	M16	300	11.0	PHF FX10-220X285
240	305	50	56	74	715	85 500	160	125	30	M16	300	12.0	PHF FX10-240X305
260	325	50	56	74	800	104 000	165	130	34	M16	300	13.0	PHF FX10-260X325
280	355	60	66	86.5	915	128 000	145	115	32	M18	410	19.0	PHF FX10-280X355
300	375	60	66	86.5	1 020	153 000	150	120	36	M18	410	20.0	PHF FX10-300X375
320	405	72	78	100.5	1 310	210 000	150	120	36	M20	590	30.0	PHF FX10-320X405
340	425	72	78	100.5	1 310	224 000	145	115	36	M20	590	30.1	PHF FX10-340X425
360	455	84	90	116	1 630	294 000	145	115	36	M22	790	42.0	PHF FX10-360X455
380	475	84	90	116	1 620	308 000	135	110	36	M22	790	44.0	PHF FX10-380X475
400	495	84	90	116	1 610	322 000	130	105	36	M22	790	46.0	PHF FX10-400X495
420	515	84	90	116	1 780	370 000	135	110	40	M22	790	50.0	PHF FX10-420X515
440	545	96	102	130	2 050	450 000	130	105	40	M24	1 000	65.0	PHF FX10-440X545
460	565	96	102	130	2 030	465 000	125	100	40	M24	1 000	67.0	PHF FX10-460X565
480	585	96	102	130	2 150	505 000	125	100	42	M24	1 000	71.0	PHF FX10-480X585
500	605	96	102	130	2 200	553 000	125	100	44	M24	1 000	73.0	PHF FX10-500X605
520	630	96	102	130	2 300	592 000	125	100	45	M24	1 000	80.0	PHF FX10-520X630
540	650	96	102	130	2 320	618 000	120	100	45	M24	1 000	82.0	PHF FX10-540X650
560	670	96	102	130	2 430	670 000	120	100	48	M24	1 000	85.0	PHF FX10-560X670
580	690	96	102	130	2 520	727 000	120	100	50	M24	1 000	88.0	PHF FX10-580X690
600	710	96	102	130	2 565	770 000	120	100	50	M24	1 000	91.0	PHF FX10-600X710
620	730	96	102	130	2 647	818 000	120	100	52	M24	1 000	93.0	PHF FX10-620X730
640	750	96	102	130	2 698	860 000	115	100	54	M24	1 000	96.0	PHF FX10-640X750
660	770	96	102	130	2 790	919 000	120	100	56	M24	1 000	99.0	PHF FX10-660X770
680	790	96	102	130	2 820	955 000	115	100	56	M24	1 000	102.0	PHF FX10-680X790
700	810	96	102	130	2 945	1 018 000	115	100	60	M24	1 000	104.0	PHF FX10-700X810
720	830	96	102	130	2 965	1 060 000	115	100	60	M24	1 000	107.0	PHF FX10-720X830
740	850	96	102	130	3 065	1 128 000	115	100	62	M24	1 000	110.0	PHF FX10-740X850
760	870	96	102	130	3 170	1 200 000	115	100	64	M24	1 000	113.0	PHF FX10-760X870
780	890	96	102	130	3 205	1 235 000	115	100	65	M24	1 000	116.0	PHF FX10-780X890
800	910	96	102	130	3 260	1 287 000	115	100	66	M24	1 000	118.0	PHF FX10-800X910

**FX20**  
d 6–130 mm

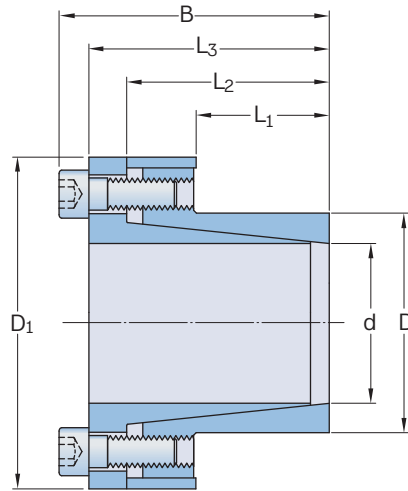

Dimensions							Performance		Pressure		Clamp screws		Weight	Designation	
d	D	L <sub>1</sub>	L <sub>2</sub>	L <sub>3</sub>	B	D <sub>1</sub>	Transmissible axial force F <sub>t</sub>	Transmissible torque M <sub>t</sub>	Shaft surface P <sub>w</sub>	Hub surface P <sub>n</sub>	Qty	Size	Tightening torque M <sub>s</sub>		
mm							kN	Nm	N/mm <sup>2</sup>	N/mm <sup>2</sup>	–	–	Nm	kg	–
6	14	10	18.5	21	24	25	4.5	13	190	80	3	M3	2	0.04	PHF FX20-6X14
7	15	12	22	25	29	27	6.5	24	230	110	3	M4	4.9	0.06	PHF FX20-7X15
8	15	12	22	25	29	27	6.65	25	210	110	3	M4	4.9	0.05	PHF FX20-8X15
9	16	14	23	26	30	28	9.98	45	210	120	4	M4	4.9	0.06	PHF FX20-9X16
10	16	14	23	26	30	28	9.98	49	180	120	4	M4	4.9	0.06	PHF FX20-10X16
11	18	14	23	26	30	32	9.98	54	170	105	4	M4	4.9	0.07	PHF FX20-11X18
12	18	14	23	26	30	32	9.98	60	155	105	4	M4	4.9	0.07	PHF FX20-12X18
13	23	14	23	26	30	38	9.98	63	145	85	4	M4	4.9	0.11	PHF FX20-13X23
14	23	14	23	26	30	38	9.98	70	135	85	4	M4	4.9	0.10	PHF FX20-14X23
15	24	16	29	36	42	45	17.1	120	185	120	3	M6	17	0.22	PHF FX20-15X24
16	24	16	29	36	42	45	17.1	140	180	120	3	M6	17	0.22	PHF FX20-16X24
17	26	18	31	38	44	47	22	180	190	125	4	M6	17	0.25	PHF FX20-17X26
18	26	18	31	38	44	47	22	200	180	125	4	M6	17	0.24	PHF FX20-18X26
19	27	18	31	38	44	49	22	210	170	120	4	M6	17	0.26	PHF FX20-19X27
20	28	18	31	38	44	50	22	220	160	115	4	M6	17	0.27	PHF FX20-20X28
22	32	25	38	45	51	54	22	250	115	80	4	M6	17	0.34	PHF FX20-22X32
24	34	25	38	45	51	56	22	270	105	75	4	M6	17	0.36	PHF FX20-24X34
25	34	25	38	45	51	56	22	290	100	75	4	M6	17	0.35	PHF FX20-25X34
28	39	25	38	45	51	61	33	465	135	100	6	M6	17	0.48	PHF FX20-28X39
30	41	25	38	45	51	62	33	510	125	90	6	M6	17	0.48	PHF FX20-30X41
32	43	25	38	45	51	65	33	540	120	90	6	M6	17	0.47	PHF FX20-32X43
35	47	32	45	52	58	69	45	790	105	80	8	M6	17	0.58	PHF FX20-35X47
38	50	32	45	52	58	72	45	860	100	75	8	M6	17	0.61	PHF FX20-38X50
40	53	32	45	52	58	75	45	900	95	70	8	M6	17	0.68	PHF FX20-40X53
42	55	32	45	52	58	78	45	950	90	70	8	M6	17	0.76	PHF FX20-42X55
45	59	45	62	70	78	86	84	1 890	110	85	8	M8	41	1.2	PHF FX20-45X59
48	62	45	62	70	78	87	84	2 010	105	80	8	M8	41	1.2	PHF FX20-48X62
50	65	45	62	70	78	92	84	2 100	100	75	8	M8	41	1.4	PHF FX20-50X65
55	71	55	72	80	88	98	94	2 600	85	65	9	M8	41	1.6	PHF FX20-55X71
60	77	55	72	80	88	104	94	2 840	75	60	9	M8	41	1.8	PHF FX20-60X77
65	84	55	72	80	88	111	94	3 070	70	55	9	M8	41	2.1	PHF FX20-65X84
70	90	65	86	96	106	119	150	5 250	90	70	9	M10	83	3.0	PHF FX20-70X90
75	95	65	86	96	106	126	150	5 600	80	65	9	M10	83	3.0	PHF FX20-75X95
80	100	65	86	96	106	131	200	8 020	100	80	12	M10	83	3.5	PHF FX20-80X100
85	106	65	86	96	106	137	200	8 500	95	75	12	M10	83	3.6	PHF FX20-85X106
90	112	65	86	96	106	144	200	9 000	90	75	12	M10	83	3.9	PHF FX20-90X112
95	120	65	86	96	106	149	230	11 000	100	80	14	M10	83	4.4	PHF FX20-95X120
100	125	65	86	96	106	154	300	15 000	120	95	18	M10	83	4.6	PHF FX20-100X125
110	140	90	114	128	140	180	290	16 000	80	65	12	M12	145	8.7	PHF FX20-110X140
120	155	90	114	128	140	198	290	17 500	70	55	12	M12	145	10.6	PHF FX20-120X155
130	165	90	114	128	140	208	384	25 000	90	70	16	M12	145	11.3	PHF FX20-130X165

**FX30**  
d6-95 mm

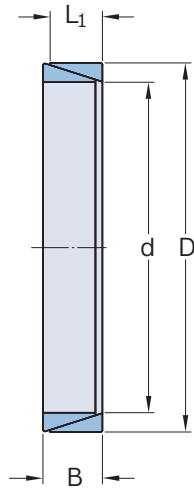

Dimensions				Performance		Pressure		Weight	Designation
d	D	L <sub>1</sub>	B	Transmissible axial force F <sub>t</sub>	Transmissible torque M <sub>t</sub>	Shaft surface P <sub>w</sub>	Hub surface P <sub>n</sub>		
mm				kN	Nm	N/mm <sup>2</sup>	N/mm <sup>2</sup>	kg	-
6	9	3.7	4.5	0.84	2.5	115	75	0.002	PHF FX30-6X9
7	10	3.7	4.5	0.86	3	105	70	0.002	PHF FX30-7X10
8	11	3.7	4.5	1.17	4.7	120	90	0.002	PHF FX30-8X11
9	12	3.7	4.5	1.76	7.9	140	105	0.002	PHF FX30-9X12
10	13	3.7	4.5	1.91	9.5	135	105	0.002	PHF FX30-10X13
12	15	3.7	4.5	1.91	11.4	115	90	0.002	PHF FX30-12X15
13	16	3.7	4.5	2.02	13.1	110	90	0.002	PHF FX30-13X16
14	18	5.3	6.3	3.18	22.3	115	90	0.005	PHF FX30-14X18
15	19	5.3	6.3	3.24	24.3	110	85	0.005	PHF FX30-15X19
16	20	5.3	6.3	3.42	27.3	105	85	0.006	PHF FX30-16X20
17	21	5.3	6.3	3.51	29.8	105	85	0.006	PHF FX30-17X21
18	22	5.3	6.3	3.61	32.4	100	80	0.007	PHF FX30-18X22
19	24	5.3	6.3	5.22	49	140	110	0.007	PHF FX30-19X24
20	25	5.3	6.3	5.33	53	135	105	0.009	PHF FX30-20X25
22	26	5.3	6.3	6	66	135	115	0.007	PHF FX30-22X26
24	28	5.3	6.3	6.13	73	130	110	0.008	PHF FX30-24X28
25	30	5.3	6.3	5.77	72	115	95	0.009	PHF FX30-25X30
28	32	5.3	6.3	6.33	86	115	100	0.01	PHF FX30-28X32
30	35	5.3	6.3	6.08	91	100	85	0.011	PHF FX30-30X35
32	36	5.3	6.3	8.24	131	130	115	0.011	PHF FX30-32X36
35	40	6.0	7.0	9.77	171	125	110	0.016	PHF FX30-35X40
36	42	6.0	7.0	9.39	169	115	100	0.021	PHF FX30-36X42
38	44	6.0	7.0	9.55	181	110	95	0.021	PHF FX30-38X44
40	45	6.6	8.0	11.57	231	115	105	0.021	PHF FX30-40X45
42	48	6.6	8.0	11.22	235	110	95	0.026	PHF FX30-42X48
45	52	8.6	10.0	15.71	353	105	95	0.045	PHF FX30-45X52
48	55	8.6	10.0	23.84	572	155	135	0.043	PHF FX30-48X55
50	57	8.6	10.0	24.08	602	150	130	0.045	PHF FX30-50X57
55	62	8.6	10.0	24.35	670	140	125	0.049	PHF FX30-55X62
56	64	10.4	12.0	28.2	790	130	115	0.07	PHF FX30-56X64
60	68	10.4	12.0	28.6	860	125	110	0.07	PHF FX30-60X68
63	71	10.4	12.0	28.8	910	120	105	0.08	PHF FX30-63X71
65	73	10.4	12.0	29.2	950	115	100	0.09	PHF FX30-65X73
70	79	12.2	14.0	39.4	1 380	125	110	0.115	PHF FX30-70X79
71	80	12.2	14.0	39.4	1 400	120	110	0.11	PHF FX30-71X80
75	84	12.2	14.0	38.6	1 450	115	100	0.12	PHF FX30-75X84
80	91	15.0	17.0	55	2 200	125	105	0.21	PHF FX30-80X91
85	96	15.0	17.0	56.4	2 400	120	105	0.21	PHF FX30-85X96
90	101	15.0	17.0	60.5	2 730	120	105	0.22	PHF FX30-90X101
95	106	15.0	17.0	64.2	3 050	120	110	0.23	PHF FX30-95X106

# FX30

d 100–500 mm

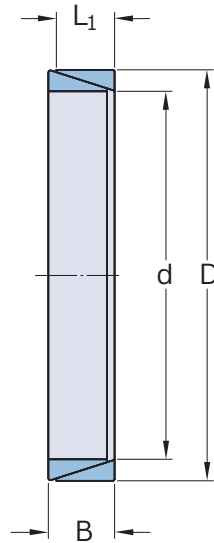

Dimensions				Performance		Pressure		Weight	Designation
d	D	L <sub>1</sub>	B	Transmissible axial force F <sub>t</sub>	Transmissible torque M <sub>t</sub>	Shaft surface P <sub>w</sub>	Hub surface P <sub>n</sub>		
mm				kN	Nm	N/mm <sup>2</sup>	N/mm <sup>2</sup>	kg	–
100	114	18.7	21	84	4 200	120	105	0.39	PHF FX30-100X114
110	124	18.7	21	93.6	5 150	120	105	0.42	PHF FX30-110X124
120	134	18.7	21	100.8	6 050	120	105	0.46	PHF FX30-120X134
130	148	25.3	28	147.6	9 600	120	105	0.86	PHF FX30-130X148
140	158	25.3	28	158.5	11 000	120	105	0.96	PHF FX30-140X158
150	168	25.3	28	172	12 900	120	105	1	PHF FX30-150X168
160	178	25.3	28	182.5	14 600	120	110	1	PHF FX30-160X178
170	191	30	33	229	19 500	120	105	1.54	PHF FX30-170X191
180	201	30	33	236	21 300	120	105	1.5	PHF FX30-180X201
190	211	30	33	255	24 200	120	110	1.8	PHF FX30-190X211
200	224	34.8	38	310	31 000	120	105	2.4	PHF FX30-200X224
210	234	34.8	38	333	35 000	120	110	2.5	PHF FX30-210X234
220	244	34.8	38	345	38 000	120	110	2.6	PHF FX30-220X244
230	257	39.5	43	408	47 000	120	105	3.4	PHF FX30-230X257
240	267	39.5	43	425	51 000	120	110	3.8	PHF FX30-240X267
250	280	44	48	415	52 000	100	90	4.8	PHF FX30-250X280
260	290	44	48	435	56 500	100	90	4.9	PHF FX30-260X290
270	300	44	48	450	61 000	100	90	5	PHF FX30-270X300
280	313	49	53	520	72 500	100	90	6.4	PHF FX30-280X313
290	323	49	53	535	77 500	100	90	6.5	PHF FX30-290X323
300	333	49	53	555	83 000	100	90	6.8	PHF FX30-300X333
320	360	59	65	710	114 000	100	90	11	PHF FX30-320X360
340	380	59	65	755	128 500	100	90	11.5	PHF FX30-340X380
360	400	59	65	800	144 000	100	90	12.3	PHF FX30-360X400
380	420	59	65	845	160 500	100	90	13	PHF FX30-380X420
400	440	59	65	890	178 000	100	90	13.7	PHF FX30-400X440
420	460	59	65	935	196 000	100	90	14.1	PHF FX30-420X460
440	480	59	65	980	215 000	100	90	14.8	PHF FX30-440X480
460	500	59	65	1 020	235 000	100	90	15.5	PHF FX30-460X500
480	520	59	65	1 070	256 000	100	90	16	PHF FX30-480X520
500	540	59	65	1 110	278 000	100	90	16.7	PHF FX30-500X540

**FX40**  
d18–180 mm

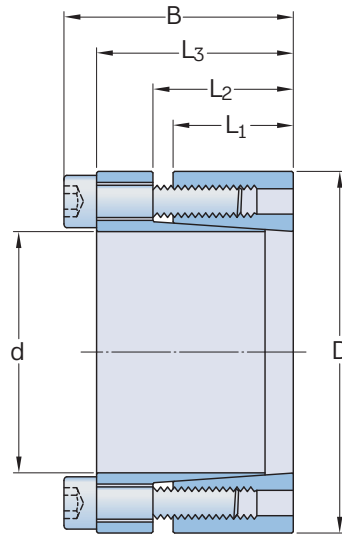

Dimensions						Performance		Pressure		Clamp screws		Tightening torque	Weight	Designation
d	D	L <sub>1</sub>	L <sub>2</sub>	L <sub>3</sub>	B	Transmissible axial force F <sub>t</sub>	Transmissible torque M <sub>t</sub>	Shaft surface P <sub>w</sub>	Hub surface P <sub>n</sub>	Qty	Size	M <sub>s</sub>	kg	–
mm						kN	Nm	N/mm <sup>2</sup>	N/mm <sup>2</sup>	–	–	Nm	kg	–
18	47	26	30	39	45	55	490	310	119	6	M6	17	0.4	PHF FX40-18X47
19	47	26	30	39	45	55	510	294	119	6	M6	17	0.4	PHF FX40-19X47
20	47	26	30	39	45	55	540	279	119	6	M6	17	0.4	PHF FX40-20X47
22	47	26	30	39	45	55	600	254	119	6	M6	17	0.4	PHF FX40-22X47
24	50	26	30	39	45	55	650	233	112	6	M6	17	0.4	PHF FX40-24X50
25	50	26	30	39	45	55	680	223	112	6	M6	17	0.4	PHF FX40-25X50
28	55	26	30	39	45	55	760	199	102	6	M6	17	0.5	PHF FX40-28X55
30	55	26	30	39	45	55	820	186	102	6	M6	17	0.5	PHF FX40-30X55
32	60	26	30	39	45	73	1 310	233	124	8	M6	17	0.6	PHF FX40-32X60
35	60	26	30	39	45	73	1 440	213	124	8	M6	17	0.5	PHF FX40-35X60
38	65	26	30	39	45	73	1 560	196	115	8	M6	17	0.6	PHF FX40-38X65
40	65	26	30	39	45	73	1 640	186	115	8	M6	17	0.6	PHF FX40-40X65
42	75	30	35	47	55	101	2 130	213	119	6	M8	41	1	PHF FX40-42X75
45	75	30	35	47	55	101	2 280	199	119	6	M8	41	1	PHF FX40-45X75
48	80	30	35	47	55	101	2 430	194	117	6	M8	41	1.1	PHF FX40-48X80
50	80	30	35	47	55	101	2 530	182	116	6	M8	41	1	PHF FX40-50X80
55	85	30	35	47	55	135	4 180	217	140	8	M8	41	1.1	PHF FX40-55X85
60	90	30	35	47	55	135	4 560	199	132	8	M8	41	1.2	PHF FX40-60X90
65	95	30	35	47	55	152	4 940	183	125	8	M8	41	1.3	PHF FX40-65X95
70	110	40	46	61	71	214	6 500	203	129	8	M10	83	2.2	PHF FX40-70X110
75	115	40	46	61	71	214	9 000	189	123	8	M10	83	2.5	PHF FX40-75X115
80	120	40	46	61	71	214	7 400	177	118	8	M10	83	2.6	PHF FX40-80X120
85	125	40	46	61	71	268	9 000	209	142	10	M10	83	2.8	PHF FX40-85X125
90	130	40	46	61	71	268	9 600	197	136	10	M10	83	2.7	PHF FX40-90X130
95	135	40	46	61	71	268	12 600	187	131	10	M10	83	2.9	PHF FX40-95X135
100	145	46	52	70	82	312	13 300	180	124	8	M12	145	3.9	PHF FX40-100X145
110	155	46	52	70	82	312	14 700	163	116	8	M12	145	4.2	PHF FX40-110X155
120	165	46	52	70	82	390	18 400	187	136	10	M12	145	4.8	PHF FX40-120X165
130	180	46	52	70	82	467	25 100	207	150	12	M12	145	5	PHF FX40-130X180
140	190	51	57	80	94	535	40 150	203	149	10	M14	230	6.5	PHF FX40-140X190
150	200	50	57	80	94	641	48 100	227	170	12	M14	230	7	PHF FX40-150X200
160	210	50	57	80	94	641	51 300	213	162	12	M14	230	7	PHF FX40-160X210
170	225	50	57	80	94	748	63 600	234	176	14	M14	230	8.5	PHF FX40-170X225
180	235	50	57	80	94	748	67 350	221	169	14	M14	230	9	PHF FX40-180X235

**FX41**  
d18–200 mm

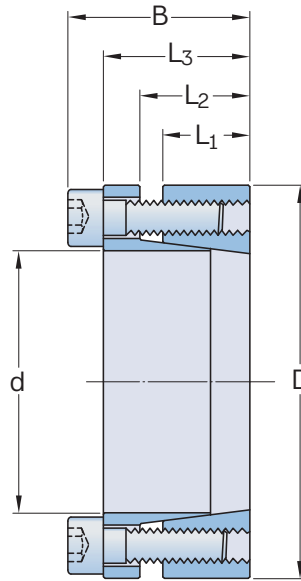

Dimensions						Performance		Pressure		Clamp screws			Weight	Designation
d	D	L <sub>1</sub>	L <sub>2</sub>	L <sub>3</sub>	B	Transmissible axial force F <sub>t</sub>	Transmissible torque M <sub>t</sub>	Shaft surface P <sub>w</sub>	Hub surface P <sub>n</sub>	Qty	Size	Tightening torque M <sub>s</sub>	kg	
mm						kN	Nm	N/mm <sup>2</sup>	N/mm <sup>2</sup>	–	–	Nm	kg	–
18	47	26	30	39	45	38	330	326	125	5	M6	14	0.3	PHF FX41-18X47
19	47	26	30	39	45	38	350	308	125	5	M6	14	0.3	PHF FX41-19X47
20	47	17	22	28	34	38	380	295	125	5	M6	14	0.3	PHF FX41-20X47
22	47	17	22	28	34	38	410	270	125	5	M6	14	0.3	PHF FX41-22X47
24	50	17	22	28	34	38	450	245	120	6	M6	14	0.3	PHF FX41-24X50
25	50	17	22	28	34	45.6	570	285	140	6	M6	14	0.3	PHF FX41-25X50
28	55	17	22	28	34	45.6	630	255	130	6	M6	14	0.4	PHF FX41-28X55
30	55	17	22	28	34	45.6	660	235	130	6	M6	14	0.4	PHF FX41-30X55
32	60	17	22	28	34	60.5	970	295	155	8	M6	14	0.4	PHF FX41-32X60
35	60	17	22	28	34	60.5	1 060	270	155	8	M6	14	0.4	PHF FX41-35X60
38	65	17	22	28	34	60.5	1 150	250	145	8	M6	14	0.5	PHF FX41-38X65
40	65	17	22	28	34	60.5	1 210	235	145	8	M6	14	0.5	PHF FX41-40X65
42	75	20	25	33	41	98	2 050	300	170	7	M8	35	0.8	PHF FX41-42X75
45	75	20	25	33	41	98	2 200	290	170	7	M8	35	0.7	PHF FX41-45X75
48	80	20	25	33	41	98	2 350	270	160	7	M8	35	0.8	PHF FX41-48X80
50	80	20	25	33	41	98	2 450	260	160	7	M8	35	0.8	PHF FX41-50X80
55	85	20	25	33	41	112	3 080	270	175	8	M8	35	0.9	PHF FX41-55X85
60	90	20	25	33	41	112	3 360	245	165	8	M8	35	0.9	PHF FX41-60X90
65	95	20	25	33	41	126	4 090	255	175	9	M8	35	1	PHF FX41-65X95
70	110	24	30	40	50	179	6 300	280	180	8	M10	70	1.9	PHF FX41-70X110
75	115	24	30	40	50	179	6 700	260	170	8	M10	70	2	PHF FX41-75X115
80	120	24	30	40	50	179	7 150	250	170	8	M10	70	2	PHF FX41-80X120
85	125	24	30	40	50	200	8 500	260	180	9	M10	70	2	PHF FX41-85X125
90	130	24	30	40	50	200	9 100	250	170	9	M10	70	2.2	PHF FX41-90X130
95	135	24	30	40	50	224	10 600	260	180	10	M10	70	2.3	PHF FX41-95X135
100	145	26	32	44	56	268	13 400	270	190	8	M12	125	3	PHF FX41-100X145
110	155	26	32	44	56	268	14 600	240	180	8	M12	125	3.2	PHF FX41-110X155
120	165	26	32	44	56	298	17 900	250	180	9	M12	125	3.4	PHF FX41-120X165
130	180	34	40	54	64	400	26 000	240	170	12	M12	125	5.2	PHF FX41-130X180
140	190	34	40	54	68	384	27 000	210	150	9	M14	190	5.4	PHF FX41-140X190
150	200	34	40	54	68	440	33 000	230	170	10	M14	190	5.7	PHF FX41-150X200
160	210	34	40	54	68	479	38 000	230	170	11	M14	190	6	PHF FX41-160X210
170	225	44	50	64	78	530	45 000	180	130	12	M14	190	8.3	PHF FX41-170X225
180	235	44	50	64	78	530	47 000	170	130	12	M14	190	8.8	PHF FX41-180X235
190	250	44	50	64	78	660	62 900	210	150	15	M14	190	10	PHF FX41-190X250
200	260	44	50	64	78	660	66	190	150	15	M14	190	10.5	PHF FX41-200X260

**FX50**  
d18–180 mm

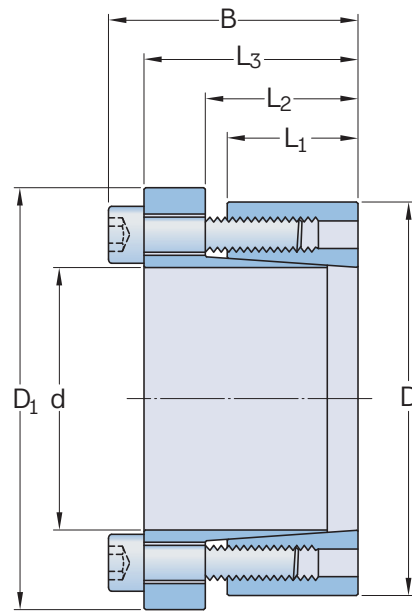

Dimensions							Performance		Pressure		Clamp screws			Weight	Designation
d	D	L <sub>1</sub>	L <sub>2</sub>	L <sub>3</sub>	B	D <sub>1</sub>	Transmissible axial force F <sub>t</sub>	Transmissible torque M <sub>t</sub>	Shaft surface P <sub>w</sub>	Hub surface P <sub>n</sub>	Qty	Size	Tightening torque M <sub>s</sub>	kg	–
mm							kN	Nm	N/mm <sup>2</sup>	N/mm <sup>2</sup>	–	–	Nm	kg	–
18	47	26	30	39	45	53	34	300	155	70	6	M6	17	0.4	PHF FX50-18X47
19	47	26	30	39	45	53	34	320	165	70	6	M6	17	0.4	PHF FX50-19X47
20	47	26	30	39	45	53	33.6	330	155	65	6	M6	17	0.5	PHF FX50-20X47
22	47	26	30	39	45	53	33.6	370	145	65	6	M6	17	0.5	PHF FX50-22X47
24	50	26	30	39	45	56	33.6	400	140	60	6	M6	17	0.5	PHF FX50-24X50
25	50	26	30	39	45	56	33.6	420	125	60	6	M6	17	0.5	PHF FX50-25X50
28	55	26	30	39	45	61	33.6	470	110	60	6	M6	17	0.6	PHF FX50-28X55
30	55	26	30	39	45	61	33.6	510	105	60	6	M6	17	0.6	PHF FX50-30X55
32	60	26	30	39	45	66	51	810	145	80	8	M6	17	0.7	PHF FX50-32X60
35	60	26	30	39	45	66	51	890	135	80	8	M6	17	0.6	PHF FX50-35X60
38	65	26	30	39	45	71	51	970	125	70	8	M6	17	0.8	PHF FX50-38X65
40	65	26	30	39	45	71	51	1 020	120	70	8	M6	17	0.6	PHF FX50-40X65
42	75	30	35	47	55	81	62.8	1 320	135	75	6	M8	41	1.2	PHF FX50-42X75
45	75	30	35	47	55	81	62.8	1 410	125	75	6	M8	41	1.1	PHF FX50-45X75
48	80	30	35	47	55	86	62.8	1 510	120	70	6	M8	41	1.3	PHF FX50-48X80
50	80	30	35	47	55	86	62.8	1 570	110	70	6	M8	41	1.1	PHF FX50-50X80
55	85	30	35	47	55	91	94.6	2 600	150	100	8	M8	41	1.2	PHF FX50-55X85
60	90	30	35	47	55	96	94.6	2 830	140	95	8	M8	41	1.3	PHF FX50-60X90
65	95	30	35	47	55	102	94.6	3 070	130	90	8	M8	41	1.4	PHF FX50-65X95
70	110	40	46	61	71	117	116	4 000	110	70	8	M10	83	2.5	PHF FX50-70X110
75	115	40	46	61	71	122	116	4 300	100	65	8	M10	83	2.6	PHF FX50-75X115
80	120	40	46	61	71	127	116	4 600	100	65	8	M10	83	2.8	PHF FX50-80X120
85	125	40	46	61	71	132	133	5 600	105	70	10	M10	83	2.8	PHF FX50-85X125
90	130	40	46	61	71	137	133	6 000	100	70	10	M10	83	3	PHF FX50-90X130
95	135	40	46	61	71	142	166.8	7 900	115	80	10	M10	83	3	PHF FX50-95X135
100	145	46	52	70	82	153	169	8 470	100	65	8	M12	145	5.5	PHF FX50-100X145
110	155	46	52	70	82	163	169	9 200	90	65	8	M12	145	4.8	PHF FX50-110X155
120	165	46	52	70	82	173	193	11 600	90	70	10	M12	145	5.5	PHF FX50-120X165
130	180	46	52	70	82	188	242	15 700	110	80	12	M12	145	6	PHF FX50-130X180
140	190	51	57	80	94	199	366	25 300	135	100	10	M14	230	7.5	PHF FX50-140X190
150	200	50	57	80	94	209	400	30 000	120	90	12	M14	230	7.7	PHF FX50-150X200
160	210	50	57	80	94	219	400	32 000	110	85	12	M14	230	8	PHF FX50-160X210
170	225	50	57	80	94	234	467	39 650	125	95	14	M14	230	8.8	PHF FX50-170X225
180	235	50	57	80	94	244	467	42 000	120	90	14	M14	230	9.8	PHF FX50-180X235

**FX51**  
d18–200 mm

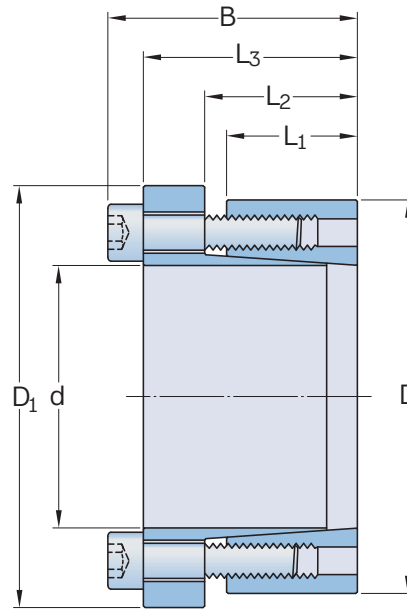

Dimensions							Performance		Pressure		Clamp screws		Weight	Designation	
d	D	L <sub>1</sub>	L <sub>2</sub>	L <sub>3</sub>	B	D <sub>1</sub>	Transmissible axial force F <sub>t</sub>	Transmissible torque M <sub>t</sub>	Shaft surface P <sub>w</sub>	Hub surface P <sub>n</sub>	Qty	Size	Tightening torque M <sub>s</sub>	kg	–
mm							kN	Nm	N/mm <sup>2</sup>	N/mm <sup>2</sup>	–	–	Nm	kg	–
18	47	17	22	28	34	54	28	250	246	94	5	M6	14	0.3	PHF FX51-18X47
19	47	17	22	28	34	54	28	270	233	93	5	M6	14	0.3	PHF FX51-19X47
20	47	17	22	28	34	54	28	280	220	95	5	M6	17	0.3	PHF FX51-20X47
22	47	17	22	28	34	54	28	300	200	95	5	M6	17	0.3	PHF FX51-22X47
24	50	17	22	28	34	57	28	330	180	90	6	M6	17	0.3	PHF FX51-24X50
25	50	17	22	28	34	57	34	420	210	105	6	M6	17	0.3	PHF FX51-25X50
28	55	17	22	28	34	62	34	470	190	95	6	M6	17	0.4	PHF FX51-28X55
30	55	17	22	28	34	62	34	500	175	95	6	M6	17	0.4	PHF FX51-30X55
32	60	17	22	28	34	67	45	720	220	115	8	M6	17	0.4	PHF FX51-32X60
35	60	17	22	28	34	67	45	790	200	115	8	M6	17	0.4	PHF FX51-35X60
38	65	17	22	28	34	72	45	850	185	105	8	M6	17	0.5	PHF FX51-38X65
40	65	17	22	28	34	72	45	900	175	105	8	M6	17	0.5	PHF FX51-40X65
42	75	20	25	33	41	82	73	1 530	225	125	7	M8	41	0.8	PHF FX51-42X75
45	75	20	25	33	41	82	73	1 650	215	125	7	M8	41	0.7	PHF FX51-45X75
48	80	20	25	33	41	87	73	1 760	200	120	7	M8	41	0.8	PHF FX51-48X80
50	80	20	25	33	41	87	73	1 830	195	120	7	M8	41	0.8	PHF FX51-50X80
55	85	20	25	33	41	92	83.5	2 300	200	130	8	M8	41	0.9	PHF FX51-55X85
60	90	20	25	33	41	97	83.5	2 510	185	125	8	M8	41	0.9	PHF FX51-60X90
65	95	20	25	33	41	102	94	3 060	190	130	9	M8	41	1	PHF FX51-65X95
70	110	24	30	40	50	117	133	4 670	210	135	8	M10	83	1.9	PHF FX51-70X110
75	115	24	30	40	50	122	133	5 000	195	125	8	M10	83	2	PHF FX51-75X115
80	120	24	30	40	50	127	133	5 300	185	125	8	M10	83	2	PHF FX51-80X120
85	125	24	30	40	50	132	148	6 300	195	135	9	M10	83	2	PHF FX51-85X125
90	130	24	30	40	50	137	148	6 750	185	130	9	M10	83	2.2	PHF FX51-90X130
95	135	24	30	40	50	142	166	7 900	195	135	10	M10	83	2.3	PHF FX51-95X135
100	145	26	32	44	56	152	194	9 700	200	140	8	M12	145	3	
110	155	26	32	44	56	162	194	10 600	180	130	8	M12	145	3.2	PHF FX51-110X155
120	165	26	32	44	56	172	216	13 000	185	135	9	M12	145	3.4	
130	180	34	40	54	64	187	290	18 900	175	125	12	M12	145	5.2	
140	190	34	40	54	68	197	290	20 500	165	120	9	M14	230	5.4	
150	200	34	40	54	68	207	333	25 000	175	130	10	M14	230	5.7	
160	210	34	40	54	68	217	362	29 000	180	135	11	M14	230	6	
170	225	44	50	64	78	232	400	34 000	140	105	12	M14	230	8.3	
180	235	44	50	64	78	242	400	36 000	135	105	12	M14	230	8.8	
190	250	44	50	64	78	257	500	47 500	160	120	15	M14	230	10	
200	260	44	50	64	78	267	500	50 000	150	115	15	M14	230	10.5	

**FX52**  
d14–50 mm

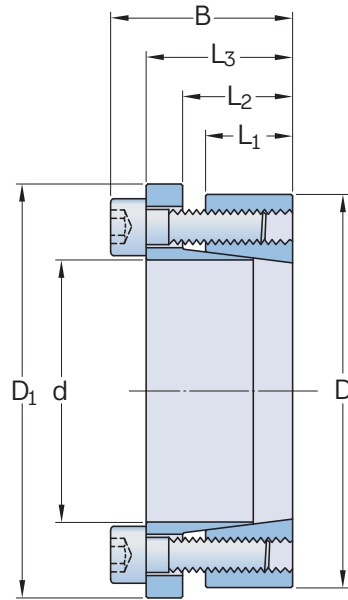

Dimensions							Performance		Pressure		Clamp screws		Weight	Designation	
d	D	L <sub>1</sub>	L <sub>2</sub>	L <sub>3</sub>	B	D <sub>1</sub>	Transmissible axial force F <sub>t</sub>	Transmissible torque M <sub>t</sub>	Shaft surface P <sub>w</sub>	Hub surface P <sub>n</sub>	Qty	Size	Tightening torque M <sub>s</sub>	kg	–
mm							kN	Nm	N/mm <sup>2</sup>	N/mm <sup>2</sup>	–	–	Nm	kg	–
<b>Normal series</b>															
14	55	17	22	30	38	62	18.1	120	205	55	3	M8	25	0.5	PHF FX52-14X55
16	55	17	22	30	38	62	18.1	140	180	55	3	M8	25	0.5	PHF FX52-16X55
18	55	17	22	30	38	62	18.1	150	160	55	3	M8	25	0.5	PHF FX52-18X55
19	55	17	22	30	38	62	18.1	160	150	55	3	M8	25	0.5	PHF FX52-19X55
20	55	17	22	30	38	62	18.1	170	145	55	3	M8	25	0.5	PHF FX52-20X55
22	55	17	22	30	38	62	25.3	280	185	75	3	M8	35	0.5	PHF FX52-22X55
24	55	17	22	30	38	62	25.3	300	170	75	3	M8	35	0.5	PHF FX52-24X55
25	55	17	22	30	38	62	25.3	310	165	75	3	M8	35	0.5	PHF FX52-25X55
28	55	17	22	30	38	62	31.4	430	175	90	3	M8	41	0.4	PHF FX52-28X55
30	55	17	22	30	38	62	31.4	470	165	90	3	M8	41	0.4	PHF FX52-30X55
<b>Medium series</b>															
24	65	17	22	30	38	72	37.4	440	245	90	5	M8	30	0.7	PHF FX52-24X65
25	65	17	22	30	38	72	37.4	460	235	90	5	M8	30	0.7	PHF FX52-25X65
28	65	17	22	30	38	72	43.6	600	245	105	5	M8	35	0.6	PHF FX52-28X65
30	65	17	22	30	38	72	43.6	640	230	105	5	M8	35	0.6	PHF FX52-30X65
32	65	17	22	30	38	72	43.6	690	215	105	5	M8	35	0.6	PHF FX52-32X65
35	65	17	22	30	38	72	52.5	910	235	130	5	M8	41	0.5	PHF FX52-35X65
38	65	17	22	30	38	72	52.5	990	220	130	5	M8	41	0.5	PHF FX52-38X65
40	65	17	22	30	38	72	52.5	1050	205	130	5	M8	41	0.5	PHF FX52-40X65
<b>Large series</b>															
30	80	20	25	33	41	87	52.4	780	235	90	7	M8	30	1	PHF FX52-30X80
32	80	20	25	33	41	87	52.4	830	220	90	7	M8	30	1	PHF FX52-32X80
35	80	20	25	33	41	87	61	1060	230	100	7	M8	35	1	PHF FX52-35X80
38	80	20	25	33	41	87	61	1150	215	100	7	M8	35	1	PHF FX52-38X80
40	80	20	25	33	41	87	61	1220	205	100	7	M8	35	0.9	PHF FX52-40X80
42	80	20	25	33	41	87	73.5	1540	235	120	7	M8	41	0.9	PHF FX52-42X80
45	80	20	25	33	41	87	73.5	1650	220	120	7	M8	41	0.8	PHF FX52-45X80
48	80	20	25	33	41	87	73.5	1760	205	120	7	M8	41	0.8	PHF FX52-48X80
50	80	20	25	33	41	87	73.5	1830	195	120	7	M8	41	0.8	PHF FX52-50X80

# FX60

d 25–400 mm

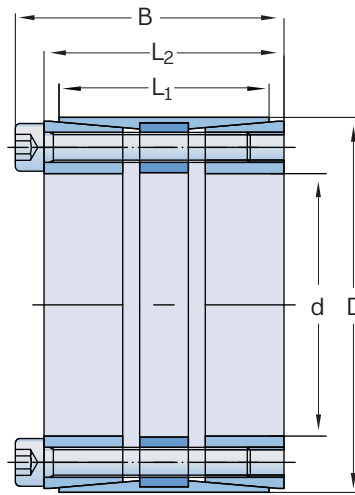

Dimensions					Performance		Pressure		Clamp screws		Weight	Designation	
d	D	L <sub>1</sub>	L <sub>2</sub>	B	Transmissible axial force F <sub>t</sub>	Transmissible torque M <sub>t</sub>	Shaft surface P <sub>w</sub>	Hub surface P <sub>n</sub>	Qty	Size	Tightening torque M <sub>s</sub>		
mm					kN	Nm	N/mm <sup>2</sup>	N/mm <sup>2</sup>	–	–	Nm	kg	–
25	50	39	45	51	79	950	245	122	6	M6	17	0.4	PHF FX60-25X50
28	55	39	45	51	59	1 102	176	78	8	M6	17	0.6	PHF FX60-28X55
30	55	39	45	51	79	1 185	219	103	8	M6	17	0.5	PHF FX60-30X55
32	60	39	45	51	76	1 200	190	107	8	M6	17	0.6	PHF FX60-32X60
35	60	39	45	51	79	1 380	187	95	8	M6	17	0.5	PHF FX60-32X60
38	65	39	45	51	99	1 494	216	109	8	M6	17	0.7	PHF FX60-35X60
40	65	39	45	51	76	1 576	205	109	8	M6	17	0.6	PHF FX60-40X65
42	75	39	45	51	146	2 997	289	140	8	M8	41	1.2	PHF FX60-42X75
45	75	56	64	72	141	3 150	175	105	8	M8	41	1.3	PHF FX60-45X75
48	80	56	64	72	171	4 100	205	101	8	M8	41	1.4	PHF FX60-48X80
50	80	56	64	72	166	4 150	158	98	8	M8	41	1.30	PHF FX60-50X80
55	85	56	64	72	166	4 550	143	93	8	M8	41	1.36	PHF FX60-55X85
60	90	56	64	72	207	6 200	164	109	10	M8	41	1.46	PHF FX60-60X90
65	95	56	64	72	207	6 750	152	104	10	M8	41	1.55	PHF FX60-65X95
70	110	70	78	88	330	11 550	179	114	10	M10	83	2.90	PHF FX60-70X110
75	115	70	78	88	330	12 350	167	109	10	M10	83	3.00	PHF FX60-75X115
80	120	70	78	88	396	15 800	188	125	11	M10	83	3.30	PHF FX60-80X120
85	125	70	78	88	396	16 800	177	120	12	M10	83	3.40	PHF FX60-85X125
90	130	70	78	88	396	17 800	167	115	12	M10	83	3.50	PHF FX60-90X130
95	135	70	78	88	396	18 800	158	111	12	M10	83	3.70	PHF FX60-95X135
100	145	90	100	112	576	28 800	170	117	11	M12	145	5.50	PHF FX60-100X145
110	155	90	100	112	576	31 700	155	110	12	M12	145	6.00	PHF FX60-110X155
120	165	90	100	112	673	40 300	165	120	14	M12	145	6.40	PHF FX60-120X165
130	180	104	116	130	791	51 400	155	112	12	M14	230	10.0	PHF FX60-130X180
140	190	104	116	130	923	64 600	168	124	14	M14	230	10.0	PHF FX60-140X190
150	200	104	116	130	1 055	79 100	179	135	15	M14	230	10.3	PHF FX60-150X200
160	210	104	116	130	1 055	84 400	168	128	16	M14	230	12.4	PHF FX60-160X210
170	225	134	146	162	1 283	109 000	149	113	14	M16	355	15.7	PHF FX60-170X225
180	235	134	146	162	1 466	132 000	161	124	15	M16	355	17.6	PHF FX60-180X235
190	250	134	146	162	1 466	139 000	153	116	16	M16	355	19.6	PHF FX60-190X250
200	260	134	146	162	1 466	146 500	145	112	16	M16	355	21.5	PHF FX60-200X260
220	285	134	146	162	1 833	201 500	165	127	18	M16	355	25.0	PHF FX60-220X285
240	305	134	146	162	2 017	242 000	166	131	20	M16	355	27.0	PHF FX60-240X305
260	325	134	146	162	2 017	262 000	154	123	21	M16	355	30.0	PHF FX60-260X325
280	355	165	177	197	2 862	400 000	164	130	18	M20	690	49.8	PHF FX60-280X355
300	375	165	177	197	3 148	472 000	169	135	20	M20	690	50.0	PHF FX60-300X375
320	405	165	177	197	3 148	503 500	158	125	21	M20	690	60.0	PHF FX60-320X405
340	425	165	177	197	3 434	583 500	162	130	22	M20	690	65.0	PHF FX60-340X425
360	455	190	202	224	3 918	705 000	152	120	21	M22	930	89.0	PHF FX60-360X455
380	475	190	202	224	4 631	880 000	170	136	22	M22	930	93.0	PHF FX60-380X475
400	495	190	202	224	4 631	926 000	162	131	24	M22	930	98.0	PHF FX60-400X495

**FX61**  
d 25–400 mm

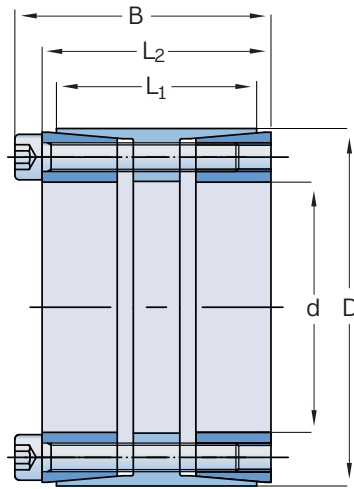

Dimensions					Performance		Pressure		Clamp screws		Weight	Designation	
d	D	L <sub>1</sub>	L <sub>2</sub>	B	Transmissible axial force F <sub>t</sub>	Transmissible torque M <sub>t</sub>	Shaft surface P <sub>w</sub>	Hub surface P <sub>n</sub>	Qty	Size	Tightening torque M <sub>s</sub>	kg	
mm					kN	Nm	N/mm <sup>2</sup>	N/mm <sup>2</sup>	–	–	Nm		–
25	50	39	45	51	79	950	245	122	6	M6	17	0.5	PHF FX61-25X50
28	55	39	45	51	59	1 102	176	78	8	M6	17	0.6	PHF FX61-28X55
30	55	39	45	51	79	1 185	219	103	8	M6	17	0.6	PHF FX61-30X55
32	60	39	45	51	76	1 200	190	107	8	M6	17	0.55	PHF FX60-32X60
35	60	39	45	51	79	1 380	187	95	8	M6	17	0.7	PHF FX61-35X60
38	65	39	45	51	99	1 494	216	109	8	M6	17	0.7	PHF FX61-38X65
40	65	39	45	51	76	1 576	205	109	8	M6	17	0.7	PHF FX61-40X65
42	75	39	45	51	146	2 997	289	140	8	M8	41	1	PHF FX61-42X75
45	75	56	64	72	141	3 150	175	105	8	M8	41	0.9	PHF FX61-45X75
48	80	56	64	72	171	4 100	205	101	8	M8	41	1.4	PHF FX61-48X80
50	80	56	64	72	171	4 270	197	101	8	M8	41	1.3	PHF FX61-50X80
55	85	56	64	72	192	5 280	202	107	8	M8	41	1.5	PHF FX61-55X85
60	90	56	64	72	214	6 410	205	112	10	M8	41	1.6	PHF FX61-60X90
65	95	56	64	72	214	6 945	190	107	10	M8	41	1.8	PHF FX61-65X95
70	110	70	78	88	339	11 800	222	107	10	M10	83	3	PHF FX61-70X110
75	115	70	78	88	339	12 700	207	112	10	M10	83	3.3	PHF FX61-75X115
80	120	70	78	88	373	14 900	213	118	11	M10	83	3.5	PHF FX61-80X120
85	125	70	78	88	407	17 300	219	123	12	M10	83	3.7	PHF FX61-85X125
90	130	70	78	88	407	18 300	207	119	12	M10	83	3.8	PHF FX61-90X130
95	135	70	78	88	407	19 300	196	114	12	M10	83	5	PHF FX61-95X135
100	145	90	100	112	544	27 100	206	110	11	M12	145	6	PHF FX61-100X145
110	155	90	100	112	593	32 600	204	113	12	M12	145	6.2	PHF FX61-110X155
120	165	90	100	112	692	41 500	218	124	14	M12	145	7.2	PHF FX61-120X165
130	180	104	116	130	817	52 800	198	115	12	M14	230	10	PHF FX61-130X180
140	190	104	116	130	949	66 400	214	127	14	M14	230	10.2	PHF FX61-140X190
150	200	104	116	130	1 017	76 200	214	130	15	M14	230	10.8	PHF FX61-150X200
160	210	104	116	130	1 085	86 700	214	132	16	M14	230	11.5	PHF FX61-160X210
170	225	134	146	162	1 319	112 000	196	116	14	M16	355	17	PHF FX61-170X225
180	235	134	146	162	1 413	127 000	198	119	15	M16	355	18.5	PHF FX61-180X235
190	250	134	146	162	1 508	143 000	200	119	16	M16	355	21.5	PHF FX61-190X250
200	260	134	146	162	1 508	150 000	190	115	16	M16	355	22	PHF FX61-200X260
220	285	134	146	162	1 696	186 000	195	118	18	M16	355	25	PHF FX61-220X285
240	305	134	146	162	1 885	226 000	198	118	20	M16	355	27	PHF FX61-240X305
260	325	134	146	162	1 979	257 000	192	121	21	M16	355	30	PHF FX61-260X325
280	355	165	177	197	2 648	370 000	197	120	18	M20	690	46	PHF FX61-280X355
300	375	165	177	197	2 942	441 000	205	126	20	M20	690	50	PHF FX61-300X375
320	405	165	177	197	3 089	494 000	202	123	21	M20	690	60	PHF FX61-320X405
340	425	165	177	197	3 236	550 000	199	122	22	M20	690	65	PHF FX61-340X425
360	455	190	202	224	3 845	692 000	193	118	21	M22	930	89	PHF FX61-360X455
380	475	190	202	224	4 028	765 000	191	118	22	M22	930	93	PHF FX61-380X475
400	495	190	202	224	4 394	878 000	198	124	24	M22	930	98	PHF FX61-400X495

**FX65**  
d100–500 mm

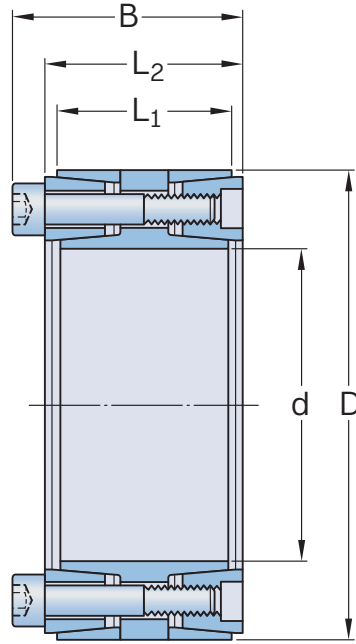

Dimensions					Performance Transmissible axial force $F_t$	Transmissible torque $M_t$	Pressure		Set screw acc. DIN912 (Grade (12,9))			Weight kg	Designation
d	D	L <sub>1</sub>	L <sub>2</sub>	B			Shaft surface $P_w$	Hub surface $P_n$	Qty	Size	$M_s$		
mm					kN	Nm	N/mm <sup>2</sup>	N/mm <sup>2</sup>	-	-	Nm		-
100	145	60	65	77	291	14 540	194	133	10	M12	145	4.10	PHF FX65-100x145
110	155	60	65	77	297	163 00	180	127	10	M12	145	4.40	PHF FX65-110x155
120	165	60	65	77	332	20 000	184	133	12	M12	145	4.80	PHF FX65-120x165
130	180	68	74	86	424	27 500	189	136	15	M12	145	6.50	PHF FX65-130x180
140	190	68	74	86	514	38 100	225	165	18	M12	145	7.00	PHF FX65-140x190
150	200	68	74	86	345	38 600	198	149	18	M12	145	7.40	PHF FX65-150x200
160	210	68	74	86	636	50 900	230	175	20	M12	145	7.80	PHF FX65-160x210
170	225	75	81	75	676	60 900	217	164	18	M14	230	10.0	PHF FX65-170x225
180	235	75	81	75	719	61 200	193	147	18	M14	230	10.6	PHF FX65-180x235
190	250	88	94	88	816	77 500	183	139	20	M14	230	14.3	PHF FX65-190x250
200	260	88	94	88	920	97 000	211	162	22	M14	230	15.0	
210	275	98	104	89	980	99 000	178	135	18	M16	355	17.5	PHF FX65-210x275
220	285	98	104	120	990	108 000	181	140	18	M16	355	19.8	
240	305	98	104	120	1300	156 000	220	174	22	M16	355	21.4	
250	315	98	104	120	1340	168 000	215	170	22	M16	355	22.0	PHF FX65-250x315
260	325	95	104	120	1420	185 000	224	179	24	M16	355	23.0	
280	355	120	126	144	1560	218 000	184	146	24	M18	475	35.2	
300	375	120	126	144	1600	241 000	176	142	24	M18	475	37.4	
320	405	135	142	162	2050	330 000	184	146	24	M20	475	51.3	
340	425	135	142	162	2080	354 000	176	140	24	M20	690	54.1	
360	455	158	165	187	2620	480 000	176	139	24	M22	930	75.4	
380	475	158	165	187	2670	498 000	163	130	25	M22	930	79.0	
400	495	158	165	187	2750	551 000	163	132	25	M22	930	82.8	
420	515	158	165	187	3170	666 000	179	148	30	M22	930	86.5	
450	555	172	180	204	3740	841 000	177	143	30	M24	1200	112	
480	585	172	180	204	3990	957 000	177	144	30	M24	1200	119	
500	605	172	180	204	3990	998 000	170	140	32	M24	1200	123	

**FX75**  
d3–40 mm

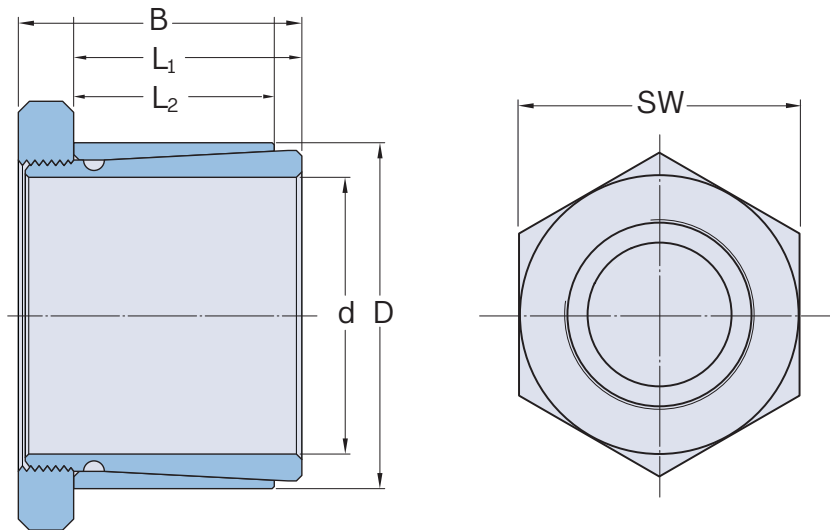

Dimensions					Performance	Locking screw			Weight	Designation
d	D	B	L <sub>1</sub>	L <sub>2</sub>	Transmissible torque M <sub>t</sub>	SW	D x TP	M <sub>s</sub>	kg	–
mm					Nm	–	–	Nm	kg	–
3	8	15	12.5	11	2.5	8	M6X0.5	7.5	0.004	PHF FX75-3X8X15
4	8	15	12.5	11	3	8	M6X0.5	7.5	0.004	PHF FX75-4X8X15
5	10	15	12.5	11	4	10	M8X0.5	10	0.004	PHF FX75-5X10X15
6	10	15	12.5	11	7	10	M8X0.5	10	0.005	PHF FX75-6X10X15
6.35	10	15	12.5	11	7	10	M8X0.5	10	0.006	PHF FX75-6.35X10X15
7	12	15	12	11	8	12	M10X0.75	9	0.010	PHF FX75-7X12X15
8	14	22	19	16.5	14	16	M12X1	15	0.018	PHF FX75-8X14X22
9	14	22	19	16.5	14	16	M12X1	15	0.017	PHF FX75-9X14X22
9.52	14	22	19	16.5	14	16	M152X1	15	0.015	PHF FX75-9.52X14X22
10	17	22	18.5	16.5	18	18	M15X1	19	0.025	PHF FX75-10X17X22
11	17	22	18.5	16.5	18	18	M15X1	19	0.025	PHF FX75-11X17X22
12	17	22	23	16.5	18	18	M15X1	19	0.020	PHF FX75-12X17X22
14	20	28	23	21	24	20	M17X1	25	0.035	PHF FX75-14X20X18
15	20	28	23	21	24	20	M17X1	25	0.030	PHF FX75-15X20X28
15.88	23	28	23	21	26	26	M20X1	27	0.030	PHF FX75-15.88X23X28
16	23	28	23	21	26	26	M20X1	27	0.040	PHF FX75-16X23X28
17	23	28	23	21	26	26	M20X1	27	0.045	PHF FX75-17X23X28
18	25	28	23	21	29	27	M22X1	37	0.055	PHF FX75-18X25X28
19	25	28	23	21	29	27	M22X1	30	0.050	PHF FX75-19X25X28
20	25	28	23	21	31	30	M25X1	32	0.070	PHF FX75-20X28X28
22	25	29	29	27	34	32	M26X1	45	0.075	PHF FX75-22X25X29
24	32	35	29	27	45	34	M28X1	51	0.095	PHF FX75-24X32X35
25	32	35	29	27	45	34	M28X1	51	0.09	PHF FX75-25X32X35
28	36	35	29	27	48	38	M32X1	55	0.095	PHF FX75-28X36X35
30	37	35	29	27	52	38	M33X1	57	0.105	PHF FX75-30X37X35
32	51	40	32	29	57	45	M37X1.5	64	0.165	PHF FX75-32X51X40
35	43	40	32	29	63	48	M39X1.25	68	0.179	PHF FX75-35X43X40
38	48	40	32	29	84	52	M43X1.5	73	0.220	PHF FX75-38X48X40
40	50	40	32	29	105	55	M45X1.5	76	0.249	PHF FX75-40X50X40

**FX80**  
d14–70 mm

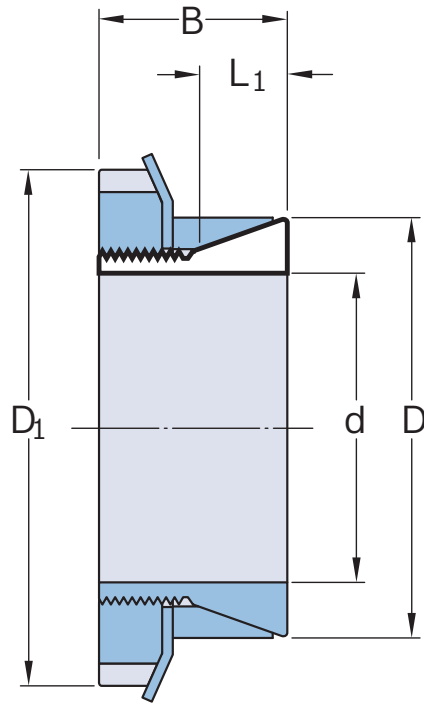

Dimensions					Performance	Transmissible	Pressure	Hub	Clamp screws		Weight	Designation
d	D	L <sub>1</sub>	B	D <sub>1</sub>	Transmissible axial force F <sub>t</sub>	torque M <sub>t</sub>	Shaft surface P <sub>w</sub>	surface P <sub>n</sub>	Nut size	Tightening torque M <sub>s</sub>	kg	
mm					kN	Nm	N/mm <sup>2</sup>	N/mm <sup>2</sup>	–	Nm		–
14	25	6.5	16.5	32	5.1	38	200	110	KM4	95	0.05	PHF FX80-14X25
15	25	6.5	16.5	32	5.5	41	185	110	KM4	95	0.05	PHF FX80-15X25
16	25	6.5	16.5	32	5.45	43	174	110	KM4	95	0.04	PHF FX80-16X25
17	26	6.5	16.5	32	5.5	47	164	107	KM4	95	0.04	PHF FX80-17X26
18	26	6.5	16.5	32	5.4	49	155	107	KM4	95	0.04	PHF FX80-18X26
19	30	6.5	18	38	6.6	62	176	112	KM5	160	0.08	PHF FX80-19X30
20	30	6.5	18	38	6.6	66	167	111	KM5	160	0.07	PHF FX80-20X30
22	32	6.5	18	38	6.6	73	152	105	KM5	160	0.1	PHF FX80-22X32
24	35	6.5	18	45	8.75	105	185	127	KM6	220	0.09	PHF FX80-24X35
25	35	6.5	18	45	8.8	110	178	127	KM6	220	0.09	PHF FX80-25X35
28	36	6.5	18	45	8.55	120	159	124	KM6	220	0.07	PHF FX80-28X36
30	40	7	19.5	52	10.6	160	164	123	KM7	340	0.07	PHF FX80-30X40
32	45	7	19.5	52	10.6	170	154	117	KM7	340	0.17	PHF FX80-32X42
35	45	8	21.5	58	13.1	230	153	120	KM8	480	0.17	PHF FX80-35X45
36	45	8	21.5	58	13.3	240	149	120	KM8	480	0.15	PHF FX80-36X45
38	48	8	21.5	58	13.1	250	141	112	KM8	480	0.15	PHF FX80-38X48
40	52	10	24.5	65	15.5	310	120	93	KM9	680	0.24	PHF FX80-40X52
42	55	10	25.5	65	15.2	320	114	87	KM9	680	0.25	PHF FX80-42X55
45	57	10	25.5	70	17.7	400	122	96	KM10	870	0.28	PHF FX80-45X57
48	62	10	25.5	75	20.8	500	135	105	KM11	970	0.32	PHF FX80-48X62
50	62	10	25.5	75	20.8	520	130	105	KM11	970	0.3	PHF FX80-50X62
55	68	12	27.5	80	22	610	103	84	KM12	1 100	0.36	PHF FX80-55X68
56	68	12	27.5	80	22	620	101	82	KM12	1 100	0.34	PHF FX80-56X68
60	73	12	28.5	85	26.6	800	113	93	KM13	1 300	0.4	PHF FX80-60X73
63	79	14	30.5	92	31.1	980	107	86	KM14	1 600	0.56	PHF FX80-63X79
65	79	14	30.5	92	31.1	1 010	104	86	KM14	1 600	0.52	PHF FX80-65X79
70	84	14	31.5	98	35.4	1 240	110	92	KM15	2 000	0.6	PHF FX80-70X84

**FX90**  
d14–60 mm

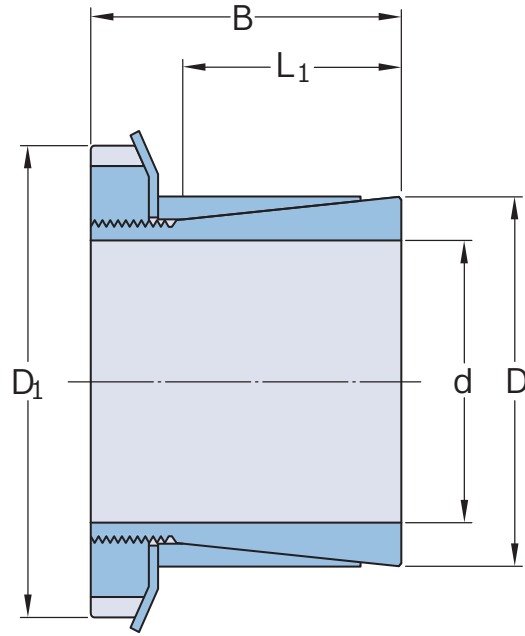

Dimensions					Performance	Pressure		Clamp screws		Weight	Designation	
d	D	L <sub>1</sub>	B	D <sub>1</sub>	Transmissible axial force F <sub>t</sub>	Transmissible torque M <sub>t</sub>	Shaft surface P <sub>w</sub>	Hub surface P <sub>n</sub>	Nut size	Tightening torque M <sub>s</sub>	kg	-
mm					kN	Nm	N/mm <sup>2</sup>	N/mm <sup>2</sup>	-	Nm		-
14	25	20	30	32	9	64	85	45	KM4	95	0.08	PHF FX90-14X25
15	25	20	30	32	9	70	80	45	KM4	95	0.08	PHF FX90-15X25
16	25	20	30	32	9	73	75	45	KM4	95	0.07	PHF FX90-16X25
17	25	20	32	32	9	80	70	45	KM4	160	0.07	PHF FX90-17X25
18	30	20	32	38	9	83	65	40	KM4	160	0.12	PHF FX90-18X30
19	30	20	32	38	11	105	75	45	KM5	160	0.12	PHF FX90-19X30
20	30	20	32	38	11	112	70	45	KM5	160	0.11	PHF FX90-20X30
22	35	25	36	45	14	163	70	45	KM6	220	0.18	PHF FX90-22X35
24	35	25	36	45	14	178	65	45	KM6	220	0.16	PHF FX90-24X35
25	35	25	36	45	14	185	60	45	KM6	220	0.15	PHF FX90-25X35
28	40	30	42	52	17	250	55	40	KM7	340	0.24	PHF FX90-28X40
30	40	30	42	52	17	270	50	40	KM7	340	0.21	PHF FX90-30X40
32	45	30	44	58	21	350	60	45	KM8	480	0.32	PHF FX90-32X45
35	45	30	44	58	21	390	55	45	KM8	480	0.26	PHF FX90-35X45
38	50	30	45	65	26	500	60	45	KM9	680	0.35	PHF FX90-38X50
40	50	30	45	65	26	520	55	45	KM9	680	0.33	PHF FX90-40X50
42	55	30	46	70	30	680	60	50	KM10	870	0.43	PHF FX90-42X55
45	55	30	46	70	30	680	60	50	KM10	870	0.39	PHF FX90-45X55
48	60	30	46	75	35	840	60	50	KM11	970	0.45	PHF FX90-48X60
50	60	30	46	75	35	880	60	50	KM11	970	0.4	PHF FX90-50X60
55	65	30	46	80	37	1 030	60	50	KM12	1 100	0.44	PHF FX90-55X65
60	70	30	52	85	45	1 360	65	55	KM13	1 300	0.55	PHF FX90-60X70

**FX120**  
d18–80 mm

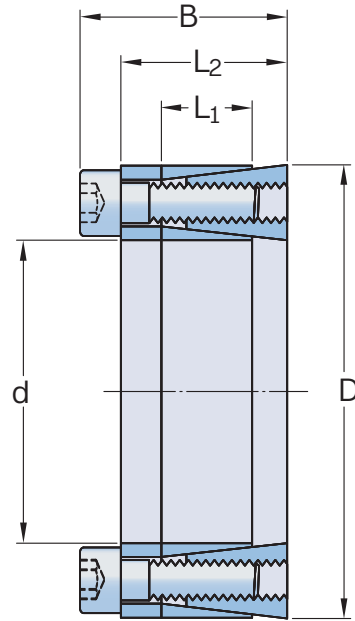

Dimensions					Performance Transmissible torque $M_t$	Pressure		Clamp screws		Tightening torque $M_s$	Weight	Designation
d	D	$L_1$	$L_2$	B		Shaft surface $P_w$	Hub surface $P_n$	Qty	Size			
mm					Nm	N/mm <sup>2</sup>	N/mm <sup>2</sup>	–	–	Nm	kg	–
18	40	12	18.5	24.5	190	260	120	6	M6	16	0.12	PHF FX120-18X40
19	41	12	18.5	24.5	210	260	120	6	M6	16	0.13	PHF FX120-19X41
20	42	12	18.5	24.5	240	250	120	6	M6	16	0.13	PHF FX120-20X42
24	46	12	18.5	24.5	290	250	120	6	M6	16	0.15	PHF FX120-24X46
25	47	12	18.5	24.5	330	230	120	8	M6	16	0.16	PHF FX120-25X47
28	50	12	18.5	24.5	370	220	120	8	M6	16	0.17	PHF FX120-28X50
30	52	12	18.5	24.5	430	210	120	8	M6	16	0.18	PHF FX120-30X52
35	57	15	22.0	28.0	610	170	100	12	M6	16	0.24	PHF FX120-35X57
38	60	15	22.0	28.0	680	170	100	12	M6	16	0.26	PHF FX120-38X60
40	62	15	22.0	28.0	780	170	100	12	M6	16	0.27	PHF FX120-40X62
42	70	18	28.0	36.0	1 480	190	110	12	M8	41	0.50	PHF FX120-42X70
45	73	18	28.0	36.0	1 500	210	130	12	M8	41	0.51	PHF FX120-45X73
48	76	18	28.0	36.0	1 550	210	130	12	M8	41	0.55	PHF FX120-48X76
50	78	18	28.0	36.0	1 650	190	120	12	M8	41	0.57	PHF FX120-50X78
55	83	18	28.0	36.0	2 000	190	120	16	M8	41	0.64	PHF FX120-55X83
60	88	18	28.0	36.0	2 350	190	120	16	M8	41	0.67	PHF FX120-60X88
70	105	22	35.0	45.0	3 900	180	120	12	M10	70	1.19	PHF FX120-70X105
80	115	22	35.0	45.0	4 800	170	120	16	M10	70	1.32	PHF FX120-80X115

**FX130**  
d15–100 mm

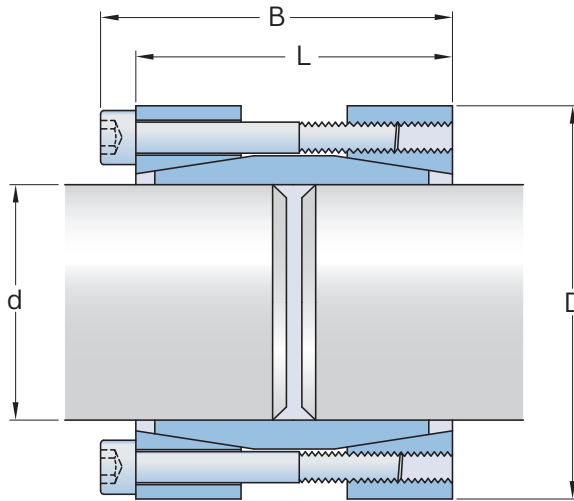

Standard

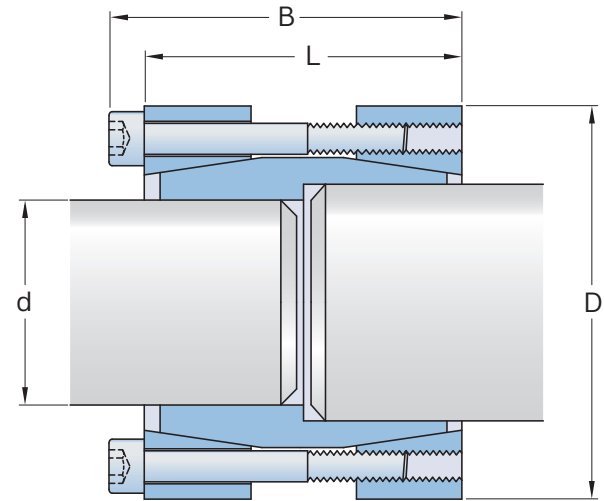

Double diameter<sup>1</sup>

Dimensions				Performance		Pressure	Clamp screws		Tightening torque	Weight	Designation
d	D	L	B	Transmissible axial force $F_t$	Transmissible torque $M_t$	Shaft surface $P_w$	Qty	Size	$M_s$	kg	
mm				kN	Nm	N/mm <sup>2</sup>	–	–	Nm		–
15	45	50	56	16	125	126	4	M6	17	0.4	PHF FX130-15X45
16	45	50	56	17	131	117	4	M6	17	0.4	PHF FX130-16X45
17	50	50	56	24.5	210	118	4	M6	17	0.5	PHF FX130-17X50
18	50	50	56	24.5	230	109	4	M6	17	0.5	PHF FX130-18X50
19	50	50	56	24.5	240	96	4	M6	17	0.5	PHF FX130-19X50
20	50	50	56	24.5	250	93	4	M6	17	0.5	PHF FX130-20X50
22	55	60	66	24.5	270	107	4	M6	17	0.6	PHF FX130-22X55
24	55	60	66	24.5	300	96	4	M6	17	0.6	PHF FX130-24X55
25	55	60	66	36.5	460	95	6	M6	17	0.6	PHF FX130-25X55
28	60	60	66	36.5	520	84	6	M6	17	0.7	PHF FX130-28X60
30	60	60	66	36.5	560	79	6	M6	17	0.7	PHF FX130-30X60
32	75	60	68	36.5	590	77	6	M6	17	0.7	PHF FX130-32X63
35	75	75	83	45.5	770	82	4	M8	41	1.3	PHF FX130-35X75
38	75	75	83	45.5	860	75	4	M8	41	1.3	PHF FX130-38X75
40	75	75	83	45.5	910	64	4	M8	41	1.3	PHF FX130-40X75
42	90	75	83	45.5	940	65	4	M8	41	2	PHF FX130-42X78
45	90	85	93	67.5	1530	73	6	M8	41	2.2	PHF FX130-45X85
48	90	85	93	67.5	1610	70	6	M8	41	2.4	PHF FX130-48X90
50	90	85	93	67.5	1700	64	6	M8	41	2.3	PHF FX130-50X90
55	105	85	93	90.5	2 460	63	8	M8	41	2.9	PHF FX130-55X94
60	105	85	93	90.5	2 720	59	8	M8	41	3.2	PHF FX130-60X100
65	105	85	93	90.5	2 940	53	8	M8	41	3	PHF FX130-65X105
70	125	100	110	107.5	3 780	50	6	M10	83	4.3	PHF FX130-70X115
75	125	100	110	107.5	4 040	47	6	M10	83	5	PHF FX130-75X125
80	125	100	110	107.5	4030	65	6	M10	83	4.7	PHF FX130-80X125
85	130	100	110	121	4260	64	8	M10	83	5.7	PHF FX130-85X130
90	135	100	110	122	4820	72	8	M10	83	6.7	PHF FX130-90X135
95	140	120	130	124	5170	67	8	M10	83	7.7	PHF FX130-95X140
100	150	120	132	127	5590	66	8	M12	145	8.7	PHF FX130-100X150

**FX140**  
d 18–90 mm

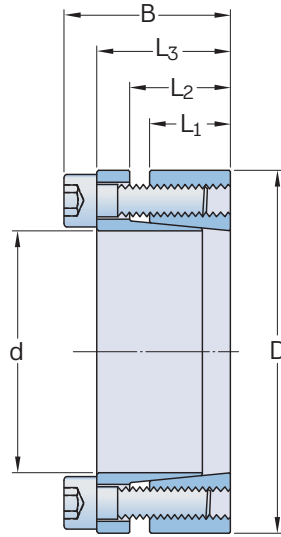

Dimensions						Performance	Transmissible	Pressure	Clamp screws			Weight	Designation	
d	D	L <sub>1</sub>	L <sub>2</sub>	L <sub>3</sub>	B	Transmissible axial force F <sub>t</sub>	torque M <sub>t</sub>	Shaft surface P <sub>w</sub>	Hub surface P <sub>n</sub>	Qty	Size	Tightening torque M <sub>s</sub>	kg	
mm						kN	Nm	N/mm <sup>2</sup>	N/mm <sup>2</sup>	–	–	Nm	kg	–
18	40	12	15	20	24	23.7	210	235	130	6	M4	5	0.2	PHF FX140-18X40
19	41	12	15	20	24	23.7	220	220	128	6	M4	5	0.2	PHF FX140-19X41
20	42	12	15	20	24	27.7	270	245	145	7	M4	5	0.2	PHF FX140-20X42
22	44	12	15	20	24	27.7	300	225	140	7	M4	5	0.2	PHF FX140-22X44
24	46	12	15	20	24	27.7	330	205	135	7	M4	5	0.2	PHF FX140-24X46
25	47	12	15	20	24	27.7	340	195	130	7	M4	5	0.2	PHF FX140-25X47
28	50	12	15	20	24	35.6	500	225	155	9	M4	5	0.2	PHF FX140-28X50
30	52	12	15	20	24	35.6	530	210	151	9	M4	5	0.2	PHF FX140-30X52
32	54	12	15	20	24	35.6	570	197	146	9	M4	5	0.2	PHF FX140-32X54
35	57	16	19	24	28	39.5	690	158	115	10	M4	5	0.3	PHF FX140-35X57
36	58	16	19	24	28	39.5	710	155	113	10	M4	5	0.3	PHF FX140-36X58
38	60	16	19	24	28	43.5	830	160	120	11	M4	5	0.3	PHF FX140-38X60
40	62	16	19	24	28	43.5	870	150	116	11	M4	5	0.4	PHF FX140-40X62
42	70	19	23	30	36	73	1 530	200	146	8	M6	17	0.6	PHF FX140-42X70
45	73	19	23	30	36	73	1 640	185	140	8	M6	17	0.6	PHF FX140-45X73
48	76	19	23	30	36	73	1 750	175	134	8	M6	17	0.6	PHF FX140-48X76
50	78	19	23	30	36	73	1 820	165	131	8	M6	17	0.6	PHF FX140-50X78
55	83	19	23	30	36	73	2 000	150	123	8	M6	17	0.7	PHF FX140-55X83
56	84	19	23	30	36	73	2 040	150	120	8	M6	17	0.7	PHF FX140-56X84
60	88	19	23	30	36	82.1	2 460	158	130	9	M6	17	0.7	PHF FX140-60X88
63	91	19	23	30	36	82.1	2 580	150	125	9	M6	17	0.9	PHF FX140-63X91
65	93	19	23	30	36	82.1	2 660	140	120	9	M6	17	1	PHF FX140-65X93
70	105	23	28	37	45	134.8	4 720	180	148	8	M8	41	1.5	PHF FX140-70X105
75	110	23	28	37	45	134.8	5 050	170	140	8	M8	41	1.5	PHF FX140-75X110
80	115	23	28	37	45	134.8	5 390	160	135	8	M8	41	1.7	PHF FX140-80X115
85	120	23	28	37	45	134.8	5 730	150	130	8	M8	41	2	PHF FX140-85X120
90	125	23	28	37	45	168.5	7 580	156	156	10	M8	41	2.3	PHF FX140-90X125

1) Double diameter versions are available upon request: contact SKF for details.

**FX195**  
d100–220 mm

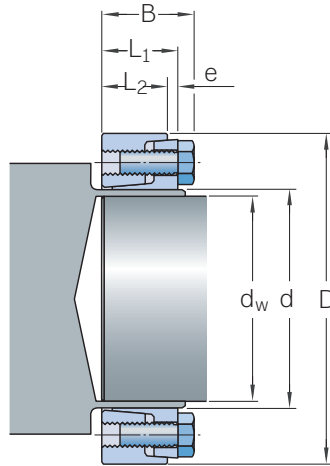

Dimensions							Performance		Set screw acc. DIN912 (Grade 12,9)				Weight	Designation
d	d <sub>w</sub>	D	L <sub>1</sub>	L <sub>2</sub>	e	B	Transmissible axial force F <sub>t</sub>	Transmissible torque M <sub>t</sub>	D <sub>1</sub>	Qty	Size	M <sub>s</sub>	kg	–
mm							kN	Nm	–	–	–	Nm	kg	–
100	70 75 80	170	50	43	7	50	213 237 261	7 400 8 900 10 400	124	12	M10	70	4.3	PHF FX195-100X170
110	80 85 90	185	57	49	8	57	314 344 375	12 600 14 600 15 900	138	10	M12	121	5.8	PHF FX195-110X185
120	85 90 95	215	60	53	8	61	320 349 378	13 600 15 700 18 000	147	12	M12	121	6.9	PHF FX195-120X215
125	90 95 100	215	61	53	8	61	365 395 426	16 400 18 800 21 300	152	12	M12	121	8.7	PHF FX195-125X215
135	95 100 110	230	67	58	9	67	427 459 525	20 300 23 000 28 900	165	10	M14	195	11	PHF FX195-123X230
140	100 105 115	230	67	58	9	67	459 492 558	23 000 25 800 32 100	170	10	M14	195	10	PHF FX195-140X230
155	110 115 125	263	71	62	9	71	565 601 672	31 100 34 500 42 000	184	12	M14	195	15	PHF FX195-155X263
165	120 125 135	290	78	68	10	78	734 776 860	44 000 48 500 58 100	198	10	M16	300	22	PHF FX195-165X290
175	130 135 145	300	78	68	10	78	834 876 962	54 000 59 000 70 000	208	12	M16	300	23	PHF FX195-175X300
185	140 145 155	320	95	85	10	95	1 157 1 210 1 319	81 000 88 000 102 000	222	14	M16	300	33	PHF FX195-185X320
200	150 155 165	340	95	85	10	95	1 279 1 333 1 442	96 000 103 000 119 000	238	16	M16	300	36	PHF FX195-200X340
220	160 170 180	370	116	103	13	116	1 615 1 749 1 883	129 000 149 000 169 000	268	16	M20	570	53	PHF FX195-220X370

# FX195

d 240–360 mm

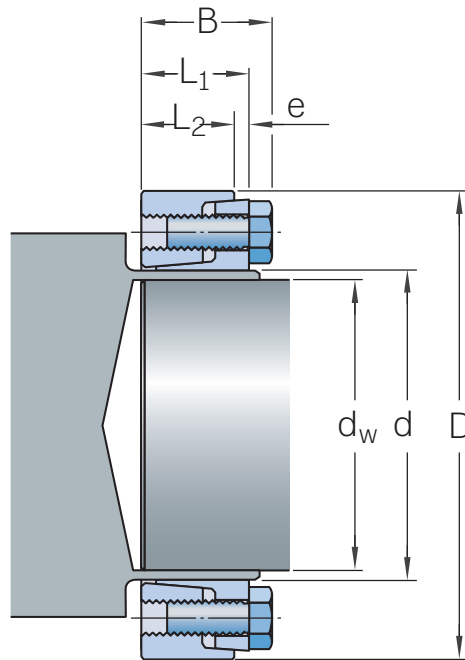

Dimensions							Performance		Set screw acc. DIN912 (Grade (12,9))				Weight	Designation
d	d <sub>w</sub>	D	L <sub>1</sub>	L <sub>2</sub>	e	B	Transmissible axial force F <sub>t</sub>	Transmissible torque M <sub>t</sub>	D <sub>1</sub>	Qty	Size	M <sub>s</sub>	kg	–
mm							kN	Nm	–	–	–	Nm	kg	–
240	170	405	120	103	13	120	1 773	151 000	288	18	M20	570	66	PHF FX195-240X405
	180						1 909	172 000						
	200						2 183	218 000						
260	190	430	132	107	13	132	2 231	212 000	312	21	M20	570	82	PHF FX195-260X430
	200						2 385	238 000						
	220						2 696	297 000						
280	210	460	145	119	13	145	2 661	279 000	334	22	M20	570	82	PHF FX195-280X460
	220						2 825	311 000						
	240						3 156	379 000						
300	220	485	155	132	15	155	2 520	332 000	360	20	M24	980	103	PHF FX195-300X485
	230						2 580	357 000						
	250						2 660	443 000						
320	240	520	155	140	15	155	3 370	404 000	380	21	M24	980	120	PHF FX195-320X520
	250						3 549	444 000						
	270						3 911	528 000						
340	250	570	170	140	15	170	3 905	480 000	402	22	M24	980	138	PHF FX195-340X580
	260						4 101	530 000						
	280						4 498	630 000						
350	270	580	177	155	15	177	4 563	625 000	414	24	M24	980	189	PHF FX195-350X580
	280						4 778	677 000						
	290						5 000	790 000						
360	270	590	177	162	15	177	4 628	625 000	424	24	M24	980	207	PHF FX195-360X590
	280						4 839	677 000						
	300						5 264	790 000						

**FX195**  
d 380–500 mm

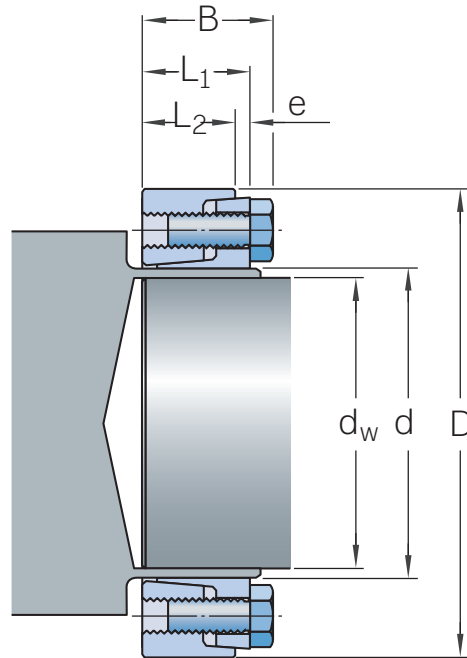

Dimensions							Performance		Set screw acc. DIN912 (Grade (12,9))				Weight	Designation
d	d <sub>w</sub>	D	L <sub>1</sub>	L <sub>2</sub>	e	B	Transmissible axial force F <sub>t</sub>	Transmissible torque M <sub>t</sub>	D <sub>1</sub>	Qty	Size	M <sub>s</sub>	kg	–
mm							kN	Nm	–	–	–	Nm	kg	–
380	290 300 310	640	183	162	17	183	5 000 5 220 5 445	725 000 783 000 844 000	454	17	M27	1 450	244	PHF FX195-380X640
390	290 300 320	650	183	166	17	183	5 384 5 611 6 069	781 000 842 000 971 000	454	18	M27	1 450	249	PHF FX195-390X650
420	320 330 350	670	203	166	17	203	6 057 6 290 6 758	969 000 1 038 000 1 183 000	486	21	M27	1 450	285	PHF FX195-420X670
440	340 350 370	740	211	186	17	211	7 128 7 382 7 891	1 212 000 1 292 000 1 460 000	506	24	M27	1 450	357	PHF FX195-440X740
460	360 370 390	770	211	194	17	211	7 739 7 995 8 511	1 393 000 1 479 000 1 660 000	534	25	M27	1 450	419	PHF FX195-460X770
480	380 390 410	800	232	213	19	232	8 721 8 993 9 542	1 657 000 1 754 000 1 956 000	552	27	M27	1 970	492	PHF FX195-480X800
500	400 410 430	850	232	213	19	232	9 435 9 717 10 283	1 887 000 1 992 000 2 211 000	572	28	M27	1 970	567	PHF FX195-500X850

**FX350**  
d10–25 mm

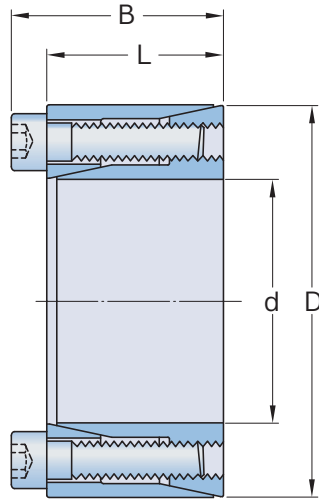

Dimensions				Performance		Pressure		Clamp screws		Tightening torque $M_s$	Weight	Designation
d	D	L	B	Transmissible axial force $F_t$	Transmissible torque $M_t$	Shaft surface $P_w$	Hub surface $P_n$	Qty	Size			
mm				kN	Nm	N/mm <sup>2</sup>	N/mm <sup>2</sup>	–	–	Nm	kg	–
10	20	13	15.5	3	15	110	55	4	M2.5	1.2	0.019	PHF FX350-10X20
12	22	13	15.5	3	20	90	50	4	M2.5	1.2	0.022	PHF FX350-12X22
14	26	17	20	5	35	105	55	4	M3	2.1	0.039	PHF FX350-14X26
15	28	17	20	6	40	100	50	4	M3	2.1	0.044	PHF FX350-15X28
16	32	17	21	9	70	130	65	4	M4	4.9	0.067	PHF FX350-16X32
18	35	21	25	9	80	115	60	4	M4	4.9	0.087	PHF FX350-18X35
19	35	21	25	9	85	110	60	4	M4	4.9	0.083	PHF FX350-19X35
20	38	21	26	16	220	220	115	6	M5	10	0.1	PHF FX350-20X38
22	40	21	26	16	240	200	110	6	M5	10	0.11	PHF FX350-22X40
24	47	26	32	23	380	220	110	6	M6	17	0.19	PHF FX350-24X47
25	47	26	32	23	390	210	110	6	M6	17	0.19	PHF FX350-25X47

**FX400**  
d 30–400 mm

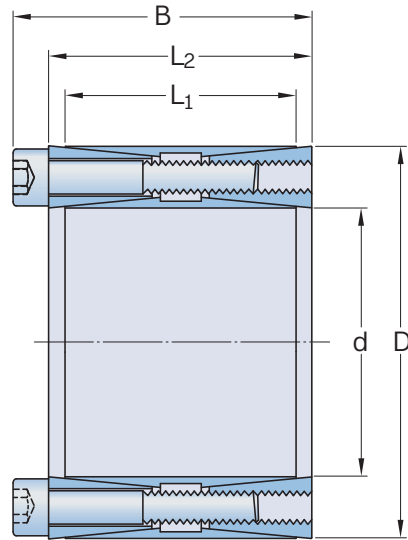

Dimensions					Performance	Transmissible torque $M_t$	Pressure		Clamp screws		Tightening torque $M_s$	Weight kg	Designation
d	D	$L_1$	$L_2$	B	Transmissible axial force $F_t$		Shaft surface $P_w$	Hub surface $P_n$	Qty	Size			
mm					kN	Nm	N/mm <sup>2</sup>	N/mm <sup>2</sup>	-	-	Nm		-
30	55	39	45	51	115	1 193	150	67	8	M6	17	0.5	PHF FX400-30X55
32	60	39	45	51	115	1 273	188	82	8	M6	17	0.6	PHF FX400-32X60
35	60	39	45	51	115	1 392	173	82	8	M6	17	0.5	PHF FX400-35X60
38	65	39	45	51	115	1 702	161	94	10	M6	17	0.6	PHF FX400-38X65
40	65	39	45	51	115	1 786	153	93	10	M6	17	0.6	PHF FX400-40X65
42	75	56	64	72	170	3 250	182	100	8	M8	41	1.2	PHF FX400-42X75
45	75	56	64	72	155	3 460	165	100	8	M8	41	1.3	PHF FX400-45X75
48	80	56	64	72	155	3 680	150	95	8	M8	41	1.5	PHF FX400-48X80
50	80	56	64	72	155	3 820	147	95	8	M8	41	1.4	PHF FX400-50X80
55	85	56	64	72	155	4 260	135	85	8	M8	41	1.5	PHF FX400-55X85
60	90	56	64	72	190	5 820	155	100	10	M8	41	1.5	PHF FX400-60X90
65	95	56	64	72	190	6 270	140	95	10	M8	41	1.6	PHF FX400-65X95
70	110	70	78	88	305	10 730	170	105	10	M10	83	3	PHF FX400-70X110
75	115	70	78	88	305	11 540	155	100	10	M10	83	3.1	PHF FX400-75X115
80	120	70	78	88	369	14 700	175	115	12	M10	83	3.5	PHF FX400-80X120
85	125	70	78	88	369	15 700	165	110	12	M10	83	3.5	PHF FX400-85X125
90	130	70	78	88	370	16 610	157	106	12	M10	83	3.8	PHF FX400-90X130
95	135	70	78	88	370	17 530	150	102	12	M10	83	4	PHF FX400-95X135
100	145	90	100	112	538	26 900	160	110	12	M12	145	6	PHF FX400-100X145
110	155	90	100	112	538	29 530	143	102	12	M12	145	6.2	PHF FX400-110X155
120	165	90	100	112	628	37 610	154	112	14	M12	145	6.8	PHF FX400-120X165
130	180	104	116	130	738	48 000	143	106	12	M14	230	9.8	PHF FX400-130X180
140	190	104	116	130	861	60 290	160	117	14	M14	230	10.2	PHF FX400-140X190
150	200	104	116	130	985	73 800	165	125	16	M14	230	10.9	PHF FX400-150X200
160	210	104	116	130	983	78 770	155	118	16	M14	230	11.5	PHF FX400-160X210
170	225	134	146	162	1 197	101 730	140	108	14	M16	355	17.2	PHF FX400-170X225
180	235	134	146	162	1 369	123 200	150	115	16	M16	355	18	PHF FX400-180X235
190	250	134	146	162	1 368	129 880	141	110	16	M16	355	21.5	PHF FX400-190X250
200	260	134	146	162	1 368	136 840	137	104	16	M16	355	22	PHF FX400-200X260
220	285	134	146	162	1 710	188 000	155	120	20	M16	355	25	PHF FX400-220X285
240	305	134	146	162	1 880	225 000	155	120	22	M16	355	27	PHF FX400-240X305
260	325	134	146	162	1 880	244 000	155	115	22	M16	355	30	PHF FX400-260X325
280	355	165	177	197	2 670	373 000	145	120	20	M20	690	46	PHF FX400-280X355
300	375	165	177	197	2 930	440 000	155	125	22	M20	690	50	PHF FX400-300X375
320	405	165	177	197	2 930	470 000	145	115	22	M20	690	60	PHF FX400-320X405
340	425	165	177	197	3 200	544 000	150	120	24	M20	690	65	PHF FX400-340X425
360	455	190	202	224	3 650	658 000	140	110	22	M22	930	89	PHF FX400-360X455
380	475	190	202	224	4 320	821 000	160	130	26	M22	930	93	PHF FX400-380X475
400	495	190	202	224	4 320	864 000	150	120	26	M22	930	98	PHF FX400-400X495

# Mounting instructions for constrictive style shaft-hub locking assemblies (FX190)

## 1. Introduction

The constrictive style of a shaft locking assembly offers a very robust, secure connection between the shaft and element hub (typically hollow shaft reducer output shafts, larger size and capacity sprockets gears etc.

- Moderate to high torque capacity
- Will accommodate axial forces
- Easy to install and dismount
- No special tools required
- Re-usable

Whereas the normal shaft-locking assembly comprises of both inner and outer rings expanding over a set of conical rings, the outer force of the shrink disc type is retained within two outer rings, (depending on style and series) machined to accommodate the taper of the inner ring.

It is then compressed onto the machined sleeve of the hub extension. The constrictive style is not mounted directly onto the transmitting shaft (see fig. 9).

The integrity and successful operation of the unit is, like most drive elements determined by correct fitting and maintenance practices.

## 2. Tolerance guidelines for FX190 series

- 2.1 Max. recommended surface finish:  $R_t$  (max)  $16 \mu\text{m}$
- 2.2 Hub outside diameter (d) tolerance<sup>1)</sup> h8
- 2.3 Shaft diameter ( $d_w$ ) tolerances<sup>1)</sup>
  - $d_w = 18-30 \text{ mm}$  H6/j6
  - $d_w \geq 30-50 \text{ mm}$  H6/h6
  - $d_w \geq 50-80 \text{ mm}$  H6/g6
  - $d_w \geq 80-500 \text{ mm}$  H7/g6

## 3. Installation (also see Section 5)

Installation and performance is dependent on a clean surface contact.

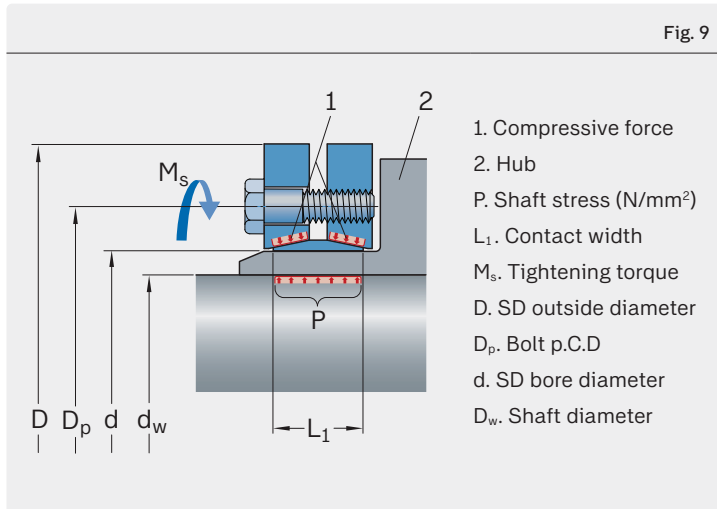

1) acc. DIN/ISO 286; Part II)

- 3.1 Clean the hub and the shaft contact areas thoroughly.
- 3.2 Apply a light oil film.
- 3.3 Slide the clamping assembly over the hollow hub.
- 3.4 Tighten the bolts in a diagonal or cross pattern in small increments, until lightly tightened all around (see fig. 10).
- 3.5 Finally tighten the bolts to the torque values for the specific bolt size and type (Grade 10.9 is standard).
- 3.6 This tightening sequence needs to be gradually repeated until the MS value shown in the tables is reached.
- 3.7 Typical torque values for the more common sizes used for this series (FX190) are shown in the table below:

## 4. Removal

The removal of the FX190 is essentially the reversal of the installation procedure detailed in section 3.

- 4.1 Loosen the bolts in a gradual sequence till all bolts are loose only. (It is not normally necessary to remove the bolts entirely from the clamping plates).
- 4.2 Gently tap the front and/or back plates for complete release. This will loosen/remove them enough from the inner tapered ring to enable the assembly to be withdrawn.

Table 7

Size	M5	M6	M8	M10	M12	M16	M24	M27
Torque [Nm]	4	12	30	59	100	250	840	1 250

## NOTE

Do not use molybdenum disulphide ( $\text{MoS}_2$ ) on any on the contact surfaces.

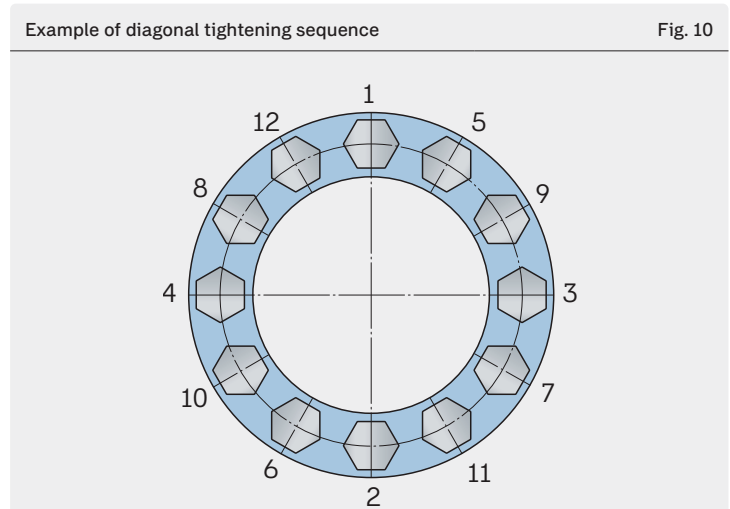

- 4.3 Inspect contact surfaces for any fretting, or wear.
- 4.4 Clean all contact surfaces of any contaminants.
- 4.5 Do not re-install if any contact surfaces damaged, marked or fretted.

## 5. General

In some instances it may be desirable to install an o-ring or seal between the two plates (see fig. 11).

This is particularly recommended in wet and/or contaminated environments.

The O-ring (not supplied with the FX190 series, unless specified) will usually (depending on the assembly size) need to be installed between the front and back (threaded) plates, prior the initial installation of the assembly.

### **⚠ CAUTION**

The procedures mentioned are general guidelines only. Company and site procedures regarding occupational health and safety should take precedence.

- Ensure all power is disconnected, and the drive isolated.
- Double check before work commences. Exposure to a bare rotating shaft can be harmful.
- Ensure all personal are familiar with the Drive Safety Checklist for a safe working environment!
- Conduct a toolbox talk prior to starting the installation - ensuring awareness of the environment, and that all parties understand the task being undertaken, highlighting any potential hazards!

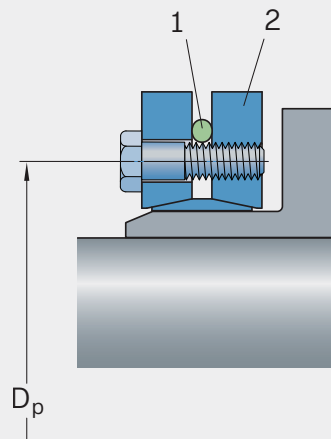

- 1. O-ring
  - 2. Threaded back plate
- $D_p$ - Bolt PCD  
(pitch circle diameter)

Fig. 11

**FX190**  
d14–170 mm

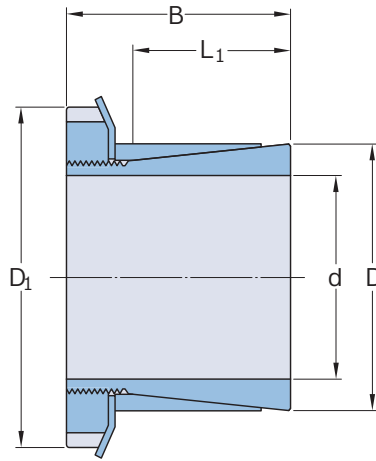

Dimensions							Performance		Clamp screws		Tightening torque $M_s$	Weight	Designation
d	d <sub>w</sub>	D	L <sub>1</sub>	L	d <sub>i</sub>	e	Transmissible axial force $F_t$	Transmissible torque $M_t$	Qty	Size			
mm							kN	Nm	–	–	Nm	kg	–
14	11 12	38	7	11.0	23	2	6 9	30 50	4	M5	4	0.1	PHF FX190-14X38
16	13 14	41	11	15.0	26	2	10 13	70 90	5	M5	4	0.1	PHF FX190-16X41
24	19 20 21	50	14	19.5	36	2.75	25 27 29	170 210 250	6	M5	4	0.2	PHF FX190-24X50
30	24 25 26	60	16	21.5	44	2.75	29 31 33	300 340 380	7	M5	4	0.3	PHF FX190-30X60
36	28 30 31	72	18	23.5	52	2.75	50 58 58	440 570 630	5	M6	12	0.4	PHF FX190-36X72
44	32 35 36	80	20	25.5	61	2.75	64 74 77	620 780 860	7	M6	12	0.6	PHF FX190-44X80
50	38 40 42	90	22	27.5	70	2.75	79 86 92	940 1160 1380	8	M6	12	0.8	PHF FX190-50X90
55	42 45 48	100	23	30.5	75	3.75	79 88 97	1160 1520 1880	8	M6	12	1.1	PHF FX190-55X100
62	48 50 52	110	23	30.5	86	3.75	100 111 117	1850 2200 2400	10	M6	12	1.3	PHF FX190-62X110
68	50 55 60	115	23	30.5	86	3.75	97 106 120	2000 2500 3150	10	M6	12	1.4	PHF FX190-68X115
75	55 60 65	138	25	32.5	100	3.75	119 137 155	2500 3200 3950	7	M8	30	1.7	PHF FX190-75X138
80	60 65 70	145	25	32.5	100	3.75	124 140 158	3200 3900 4600	7	M8	30	1.9	PHF FX190-80X145
85	65 70 75	155	30	39.0	114	4.5	175 195 216	4800 6100 7400	10	M8	30	3.5	PHF FX190-85X155

Dimensions							Performance	Transmissible	Clamp screws		Tightening	Weight	Designation
d	d <sub>w</sub>	D	L <sub>1</sub>	L	d <sub>1</sub>	e	Transmissible axial force F <sub>t</sub>	torque M <sub>t</sub>	Qty	Size	torque M <sub>s</sub>		
mm							kN	Nm	–	–	Nm	kg	–
90	65 70 75	155	30	39.0	114	4.5	170 190 210	4 750 6 000 7 250	10	M8	30	3.3	PHF FX190-90X155
100	70 75 80	170	34	44.0	124	5	195 220 240	6 900 7 500 9 000	12	M8	30	4.7	PHF FX190-100X170
110	75 80 85	185	39	50.0	136	5.5	229 252 262	7 200 9 000 10 800	9	M10	59	5.9	PHF FX190-110X185
115	80 85 90	188	39	50.0	141	5.5	235 259 269	7 400 9 200 11 100	9	M10	59	5.5	PHF FX190-115X188
120	80 85 90	215	42	54.0	160	6	285 314 340	10 600 13 300 14 500	12	M10	59	9	PHF FX190-120X215
125	85 90 95	215	42	54.0	160	6	296 324 352	11 000 13 000 15 000	12	M10	59	8.3	PHF FX190-125X215
130	90 95 100	215	42	54.0	160	6	304 333 362	11 300 13 300 15 400	12	M10	59	8	PHF FX190-130X215
140	95 100 105	230	46	60.5	175	7.25	367 396 425	15 100 17 600 20 100	10	M12	100	10	PHF FX190-140X230
155	105 110 115	265	50	64.5	192	7.25	447 478 509	22 000 25 000 28 000	12	M12	100	15	PHF FX190-155X265
160	110 115 120	265	50	64.5	192	7.25	460 490 520	22 600 25 700 28 800	12	M12	100	14.5	PHF FX190-160X265
165	115 120 125	290	56	71.0	210	7.5	595 630 655	31 000 35 000 39 000	8	M16	250	22	PHF FX190-165X290
170	120 125 130	290	56	71.0	210	7.5	610 640 670	31 900 36 000 40 100	8	M16	250	21	PHF FX190-170X290

**FX190**  
d 175–480 mm

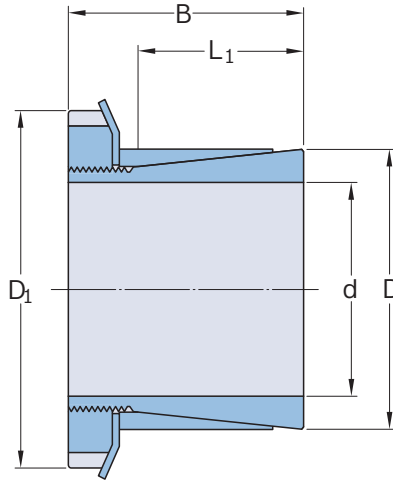

Dimensions							Performance		Clamp screws		Tightening torque $M_s$	Weight	Designation
d	d <sub>w</sub>	D	L <sub>1</sub>	L	d <sub>1</sub>	e	Transmissible axial force $F_t$	Transmissible torque $M_t$	Qty	Size			
mm							kN	Nm	–	–	Nm	kg	–
175	125 130 135	300	56	71.0	220	7.5	605 369 675	36 000 41 000 45 000	8	M16	250	22	PHF FX190-175X300
180	130 135 140	330	71	86.0	236	7.5	778 819 861	52 000 57 000 62 000	8	M16	250	21	PHF FX190-180X330
185	135 140 145	330	71	86.0	236	7.5	778 819 861	52 000 57 000 62 000	10	M24	250	37	PHF FX190-185X330
190	140 145 150	330	71	86.0	236	7.5	800 840 885	63 500 58 700 63 800	10	M16	250	36	PHF FX190-190X330
195	140 150 155	350	71	86.0	246	7.5	933 1 025 1 071	65 000 76 000 81 500	12	M16	250	41	PHF FX190-195X350
200	150 155 160	350	71	86.0	246	7.5	990 1 035 1 080	74 000 80 000 86 000	12	M16	250	41	PHF FX190-200X350
220	160 165 170	370	88	104.0	270	8	1 190 1 239 1 290	95 000 102 000 110 000	15	M16	250	54	PHF FX190-220X370
240	170 180 190	405	92	109	295	8.5	1 464 1 576 1 675	120 000 138 000 156 000	12	M20	490	67	PHF FX190-240X405
260	190 200 210	430	103	120	321	8.5	1 760 1 880 2 010	164 000 184 000 205 000	14	M20	490	82	PHF FX190-260X430
280	210 220 230	460	114	134	346	10	2 090 2 220 2 350	217 000 244 000 270 000	16	M20	490	102	PHF FX190-280X460
300	230 240 245	485	122	142	364	10	2 431 2 567 2 636	275 000 295 000 315 000	18	M20	490	118	PHF FX190-300X485

Dimensions							Performance		Clamp screws		Weight	Designation	
d	d <sub>w</sub>	D	L <sub>1</sub>	L	d <sub>1</sub>	e	Transmissible axial force F <sub>t</sub>	Transmissible torque M <sub>t</sub>	Qty	Size	Tightening torque M <sub>s</sub>	kg	–
mm							kN	Nm	–	–	Nm	kg	–
320	240 250 260	520	122	142	386	10	2 647 2 786 2 900	312 000 340 000 374 000	20	M20	490	131	PHF FX190-320X520
340	250 260 270	570	134	156	408	11	3 119 3 249 3 400	390 000 422 500 460 000	24	M20	490	186	PHF FX190-340X570
350	270 280 285	580	140	162	432	11	3 276 3 430 3 500	442 000 480 000 500 000	24	M20	490	195	PHF FX190-350X580
360	280 290 295	590	140	162	432	11	3 310 3 461 3 536	463 000 502 000 522 000	24	M20	490	204	PHF FX190-360X590
380	290 300 310	645	144	168	458	12	3 910 4 080 4 248	567 000 610 000 658 000	20	M24	840	239	PHF FX190-380X645
390	300 310 320	660	144	168	468	12	4 160 4 330 4 484	624 000 671 000 718 000	21	M24	840	260	PHF FX190-390X660
400	315 320 330	680	144	168	480	12	4 260 4 345 4 500	670 000 695 000 744 000	21	M24	840	280	PHF FX190-400X680
420	330 340 350	690	164	188	504	12	4 850 5 040 5 220	780 000 840 000 900 000	24	M24	840	316	PHF FX190-420X690
440	340 350 360	750	177	202	527	12.5	4 740 4 910 5 090	806 000 860 000 917 000	24	M24	840	408	PHF FX190-440X750
460	360 370 380	770	177	202	547	12.5	5 670 5 860 6 050	1 000 000 1 070 000 1 140 000	28	M24	840	420	PHF FX190-460X770
480	380 390 400	800	188	213	570	12.5	6 150 6 350 6 550	1 170 000 1 240 000 1 310 000	30	M24	840	505	PHF FX190-480X800

Notes





